

**HEG250 ISO 6022**  
**HYDRAULIC CYLINDERS**



- Compliant with ISO6022 & DIN24333 specification
- Maximum working pressure is 25MPa (250kgf/cm<sup>2</sup>)
- Structure: Cover fix on flange plate with screw, and easy disassembly for maintenance
- Strictly control the machining accuracy, it has the advantages of low friction and long life
- Can be used in engineering design, such as steel, metallurgy, ships and other machines
- External dimensions similar to cylinders MMB of Parker's company

**TYPE**

Type	Mark	Graphics	Dust cover	Heat resistance	Bore
Double acting cylinder	HEG250-A		HEG250-AH	HEG250-AJ	50~320
Double rod cylinder	HEG250-C		HEG250-CH	HEG250-CJ	
Double acting cylinder with adjustable stroke	HEG250-D		HEG250-DH	HEG250-DJ	

**THEORETICAL  
OUTPUT TABLE**

		Bore (mm)		50	63	80	100	125	160	200	250	320
Piston pressure area (cm <sup>2</sup> )	Extend			19.6	31.2	50.3	78.5	122.7	201.1	314.2	490.9	804.2
	Retract	Rod	class C	11.6	18.6	30.6	47.4	72.5	122.5	191.4	289.8	490.1
			class B	9.5	15.3	25.6	40.1	59.1	106.0	160.2	236.4	424.1
theoretical output (kgf)	Pressure 70 (kgf/cm <sup>2</sup> )	Extend		1374	2182	3519	5498	8590	14074	21991	34361	56297
		Retract	class C	811	1302	2144	3316	5072	8577	13401	20287	34306
	class B		662	1069	1794	2804	4137	7422	11215	16548	29688	
	Pressure 160 (kgf/cm <sup>2</sup> )	Extend		3142	4988	8042	12566	19635	32170	50265	78540	128680
		Retract	class C	1855	2977	4901	7579	11592	19604	30631	46370	78414
	class B		1513	2443	4102	6409	9456	16965	25635	37825	67858	
	Pressure 250 (kgf/cm <sup>2</sup> )	Extend		4909	7793	12566	19635	30680	50265	78540	122718	201062
		Retract	class C	2898	4652	7658	11842	18113	30631	47860	72453	122522
	class B		2364	3817	6409	10014	14775	26507	40055	59101	106029	

Tie-rod Hydraulic Cylinder

Mold Hydraulic Cylinders

Swivel & Clamp Hydraulic Cylinders

Booster Cylinders & Unclamping cylinders

**INSTALLATION FORM**

Mark	Type	Graphics	Mark	Type	Graphics
MOO (SD)	Basic		MP5 (CAB)	Clevis (with ball bearing)	
MF3 (FA)	Rod Round Flange		MS2 (LA)	Foot flange	
MF4 (FB)	Head Round Flange		MT4 (TC)	Mid Trunnion	
MP3 (CA)	Clevis				

ISO Specifications Cylinders

Round Hydraulic Cylinders

Specific Hydraulic Cylinders

Systems & Fittings

**PORT AND CUSHION POSITIONS**

■ Bore :  $\varnothing 50 \sim \varnothing 160$

M00(SD) Basic	MS2(LA) Foot flange
<p>M00(SD): Standard location A = input port B = cushion position D = check valve position</p>	<p>MS2(LA): representation : HEG250A-MS2-C-100x200-B-A B = input port A = cushion position</p>

■ Bore :  $\varnothing 200 \sim \varnothing 320$

M00(SD) Basic	MS2(LA) Foot flange
<p>M00(SD): Standard location A = input port B = Buffer adjustment and position of check valve and escape vent</p>	<p>MS2(LA): representation : HEG250A-MS2-C-100x200-B-A B = input port A = Buffer adjustment and position of check valve and escape vent</p>

**SPEC. OF OIL INLET**

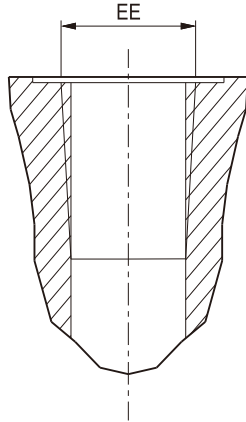
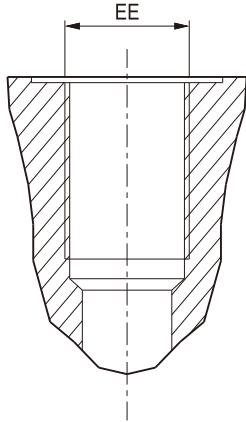
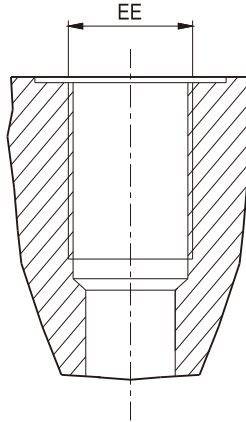
Type	RC Taper	G Parallel	M Straight
Graphics			
Bore	EE	EE	EE
50	RC1/2	G1/2	M22x1.5
63	RC3/4	G3/4	M27x2
80			
100	RC1	G1	M33x2
125			
160	RC1 1/4	G1 1/4	M42x2
200			
250	RC1 1/2	G1 1/2	M50x2
320	RC2	G2	M60x2

Tie-rod Hydraulic Cylinder

Mold Hydraulic Cylinders

Swivel & Clamp Hydraulic Cylinders

Booster Cylinders & Unclamping cylinders

ISO Specifications Cylinders

Round Hydraulic Cylinders

Specific Hydraulic Cylinders

Systems & Fittings

## SPEC. OF OIL INLET

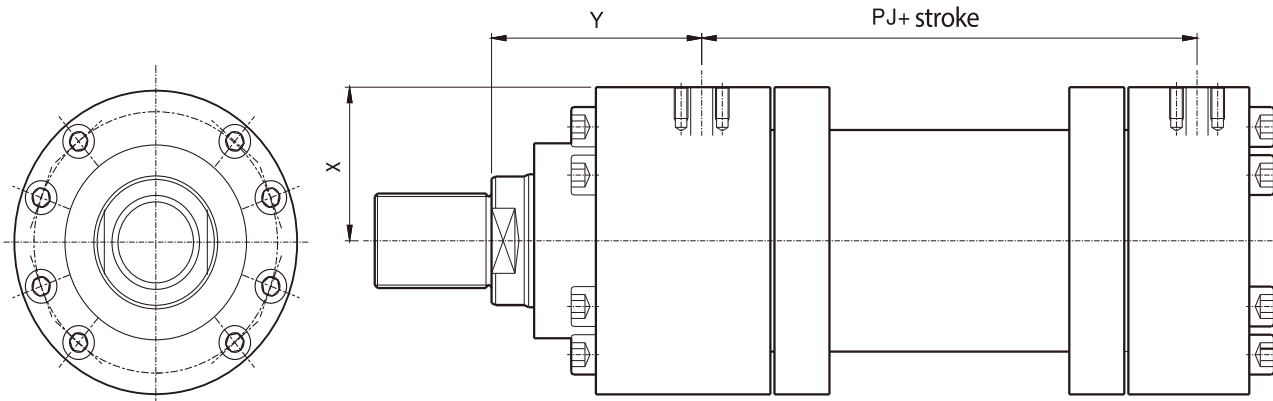

● ISO 6164 (Square Flange Oil Inlet)

● ISO 6162 (Rectangle Flange Oil Inlet)

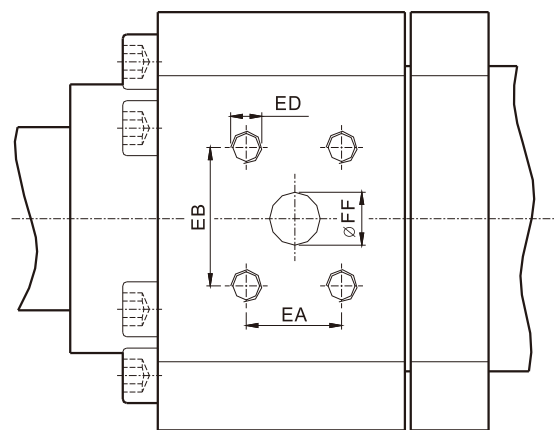
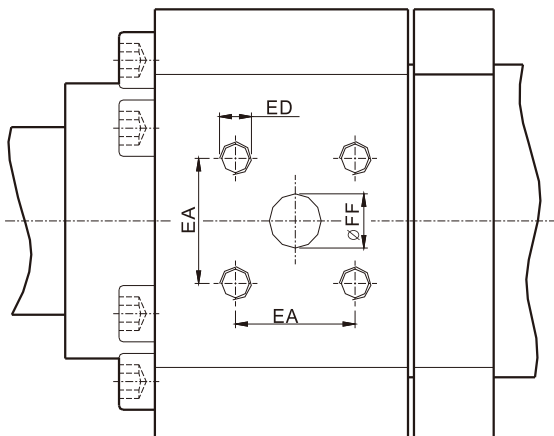

Symbol Bore	ISO 6162-1 (200-350 BAR)							ISO 6164 (250 BAR)				
	Y	PJ	X	FF	EB ±0.25	EA ±0.25	ED	Y	PJ	X	EA ±0.25	ED
50	-	-	-	-	-	-	-	97	122	48	24.7	M6x1.0
63	111	135	55	13	38.1	17.5	M8x1.25	111	135	57	29.7	M8x1.25
80	123.5	148	68	13	38.1	17.5	M8x1.25	123.5	148	69.5	29.7	M8x1.25
100	133	173	79.5	19	47.6	22.3	M10x1.5	133	173	81.5	35.4	M10x1.5
125	153	205	97.5	19	47.6	22.3	M10x1.5	157	197	100	35.4	M10x1.5
160	181.5	242	127	25	52.4	26.2	M10x1.5	181.5	242	128.5	43.8	M10x1.5
200	219	280	146.5	25	52.4	26.2	M10x1.5	220	278	148.5	43.8	M10x1.5
250	257	326	189	32	58.7	30.2	M10x1.5	257	326	192	51.6	M12x1.75
320	282	391	236	32	58.7	30.2	M10x1.5	282	391	240	51.6	M12x1.75

## INTERNAL STRUCTURE AND PART NAMES

- Bore : $\varnothing 50\sim\varnothing 160$

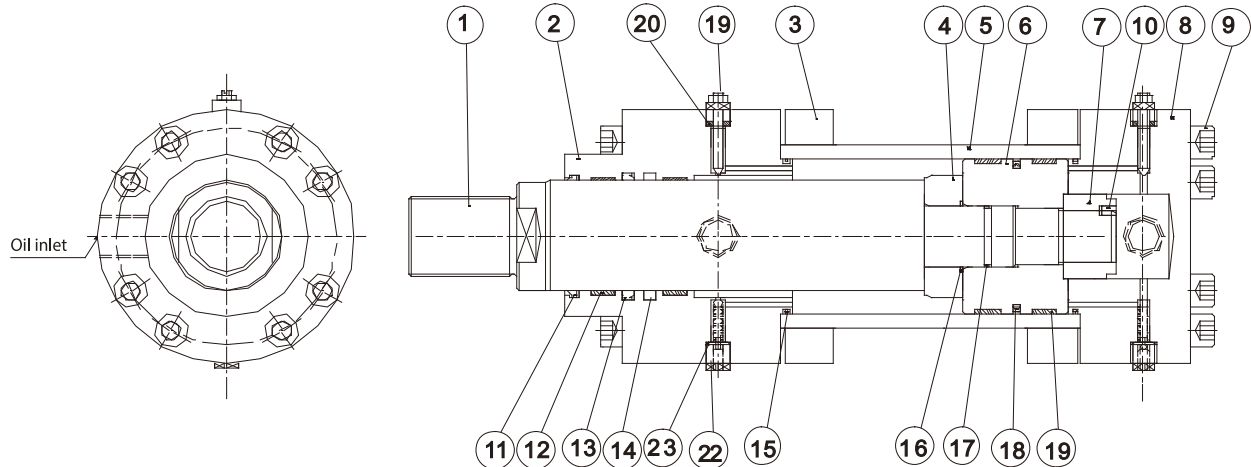

- Bore : $\varnothing 200\sim\varnothing 320$

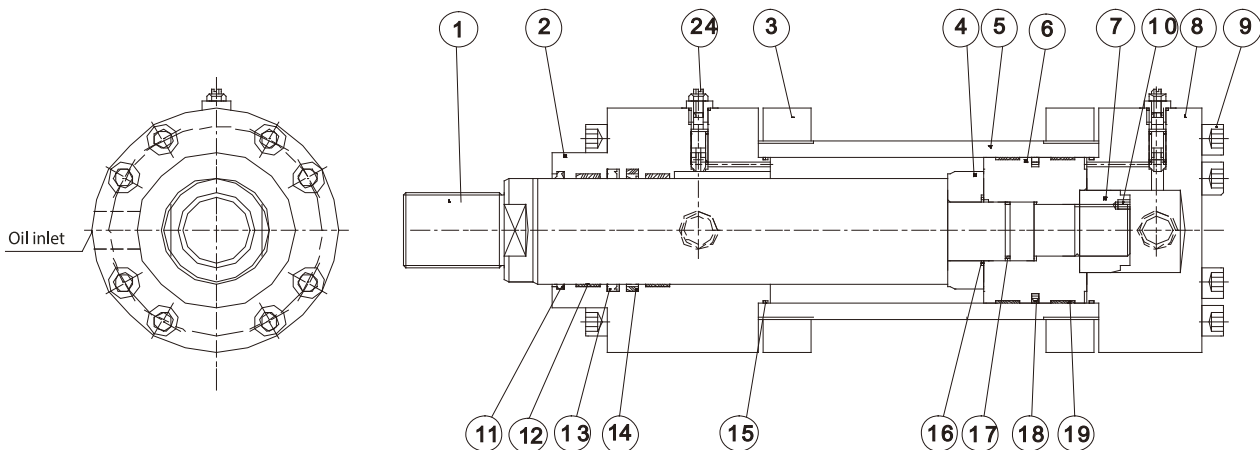

Tie-rod Hydraulic Cylinder

Mold Hydraulic Cylinders

Swivel & Clamp Hydraulic Cylinders

Booster Cylinders & Unclamping cylinders

ISO Specifications Cylinders

Round Hydraulic Cylinders

Specific Hydraulic Cylinders

Systems & Fittings

item	part name	qty	item	part name	qty
①	piston rod	1	⑬	rod cover seal	1
②	rod cover	1	⑭	rod cover plane seal(note2)	1
③	tube flange	2	⑮	cover O-ring	2
④	rod cushion	1	⑯	buffer O-ring	1
⑤	tube	1	⑰	O-ring inside piston	1
⑥	piston	1	⑱	piston seal	2
⑦	head buffer	1	⑲	piston wear ring	2
⑧	head cover	1	⑳	cushion adjusting valve ( $\varnothing 50\sim\varnothing 160$ )	2
⑨	steel screw	note1	㉑	cushion gasket ( $\varnothing 50\sim\varnothing 160$ )	2
⑩	set screw	1	㉒	check valve and escape valve ( $\varnothing 50\sim\varnothing 160$ )	2
⑪	rod cover dust seal	1	㉓	check valve O-ring ( $\varnothing 50\sim\varnothing 160$ )	2
⑫	rod cover wear ring	2	㉔	cushion and check valve ( $\varnothing 200\sim\varnothing 320$ )	2

Note 1: The number of steel screws is adjusted for different cylinder diameters.

Note 2: Front cover sleeve selection: ⑬ U-shaped sleeve is the standard specification if you need to choose ⑭ flat cover please specify.

**SEAL SPECIFICATION**

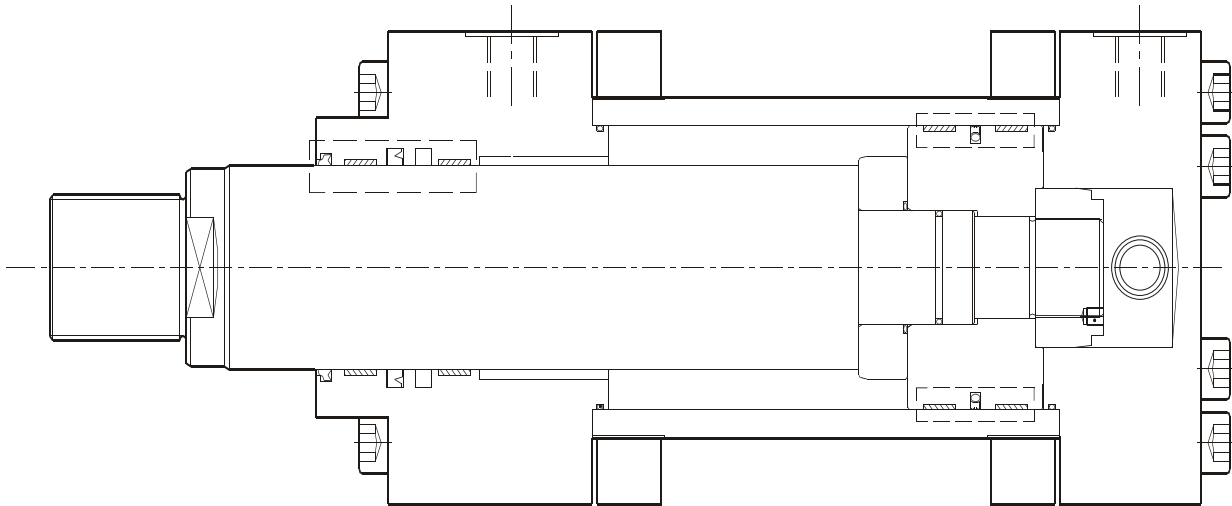

Rod seal:

Standard seal	
Servo low friction seal	
V-seal	

Piston seal :

Servo low friction seal	
V-seal	

■ JUFAN provides a variety of oil seal forms, customers can choose the right oil seal according to the working condition, if there are other special requirements, you can call the company for consultation.

**AV-PRESSURE GAUGE AND  
QUICK EXHAUST FITTING**

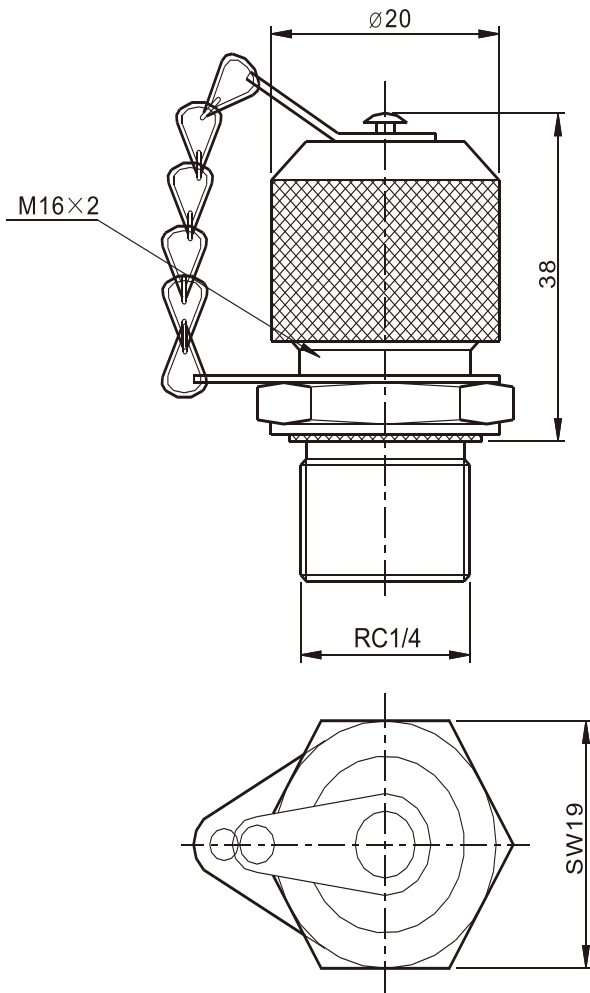

- This fitting is used for venting and pressure measurement
- When measuring the pressure, unscrew then install the pressure gauge, and measure the internal pressure of the cylinder
- This part can also be used for venting and can be used without disassembly.

Tie-rod Hydraulic Cylinder

Mold Hydraulic Cylinders

Swivel & Clamp Hydraulic Cylinders

Booster Cylinders & Unclamping cylinders

ISO Specifications Cylinders

Round Hydraulic Cylinders

Specific Hydraulic Cylinders

Systems & Fittings



**PR..CE BALL JOINT (COMPLIANCE WITH ISO-6982 OR DIN24338)**

- PR...CE(GIHN...K...LO)

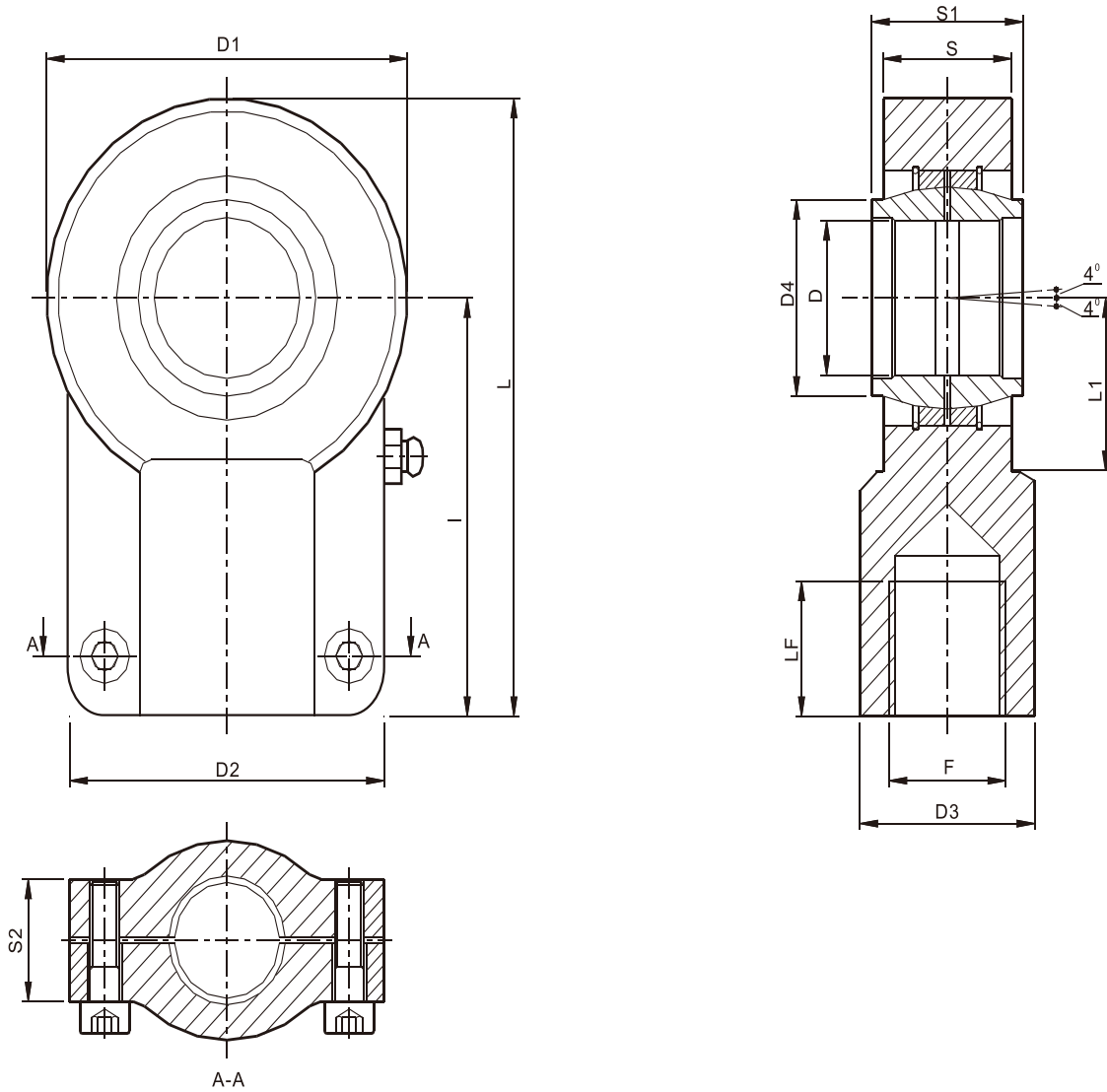

Bore	Series	F	D	S1	I	LF	D1	D2	D3	D4	S	S2	L	L1
50	PR32CE	M27x2	32	32	80	37	71	66	38	38	27.5	22	119	32
63	PR40CE	M33x2	40	40	97	46	90	80	47	46	33	27	146	41
80	PR50CE	M42x2	50	50	120	57	109	96	58	57	41	32	180	50
100	PR63CE	M48x2	63	63	140	64	132	114	70	71.5	53	38	212	62
125	PR80CE	M64x3	80	80	180	86	169	148	90	91	67	48	271	78
160	PR100CE	M80x3	100	100	212	96	211	178	110	113	86	64	323	98
200	PR125CE	M100x3	125	125	260	113	269	200	135	138	105	74	406	120
250	PR160CE	M125x4	160	160	310	126	326	250	165	177	130	82	488	150
320	PR200CE	M160x4	200	200	390	161	418	320	215	221	167	105	620	195

**ORDER INDICATION**

HEG250	A		M00	C	100	200ST
series	type	performance	installation form	shaft diameter	bore	stroke
ISO-6022 Round cylinders	A: Double acting cylinder	blank = indicates standard H: shaft with dust cover J: heat/acid & alkali resistance	M00: Basic (SD)	C:C class	50:50mm	customized
	C: Double rod cylinder		MF3: Rod Round Flange (FC)	B:B class	63:63mm	
	D: Double acting cylinder with adjustable stroke		MF4: Head Round Flange (FD)		80:80mm	
		MP3: Clevis (CA)	100:100mm			
		MP5: Clevis + Ball joint (CAB)	125:125mm			
		MS2: Foot Flange (LA)	160:160mm			
		MT4: Mid Trunnion (TC)	200:200mm			
	250:250mm					
	320:320mm					

					RC	
shaft end joint	cushion	adjustable stroke	port position	cushion position	Spec. of oil inlet	pressure joint
blank = indicates standard (not attached) PR...CE ball joint (Compliance with ISO-6982 or DIN24338) pls refer to P. 391	blank = indicates standard (no cushion) B: cushion on both ends R: cushion on rod cover H: cushion on head cover	 Unlimited adjustable length for double acting cylinder with adjustable stroke	indicates standard: same as external dimension special type: pls refer to P.385	pls refer to P.385	RC: Taper G: Parallel M: Straight MM: Rectangle	blank = indicates standard (not attached) AV: Pressure gauge and quick exhaust fitting

HEG250	A	M00	32	100	B	rod cover	
series	type	installation form	bore	stroke	shaft diameter	part name	
ISO-6022 Round cylinders	A: Double acting cylinder	M00: Basic (SD) MF3: Rod Round Flange (FC) MF4: Head Round Flange (FD) MP3: Clevis (CA) MP5: Clevis + Ball joint (CAB) MS2: Foot Flange (LA) MT4: Mid Trunnion (TC)			C:C class	refer to internal structure and part name	
	C: Double rod cylinder				B:B class		
	D: Double acting cylinder with adjustable stroke						

Tie-rod Hydraulic Cylinder

Mold Hydraulic Cylinders

Swivel & Clamp Hydraulic Cylinders

Booster Cylinders & Unclamping cylinders

ISO Specifications Cylinders

Round Hydraulic Cylinders

Specific Hydraulic Cylinders

Systems & Fittings

## EXTERNAL DIMENSIONS

- M00(SD) double acting(basic)

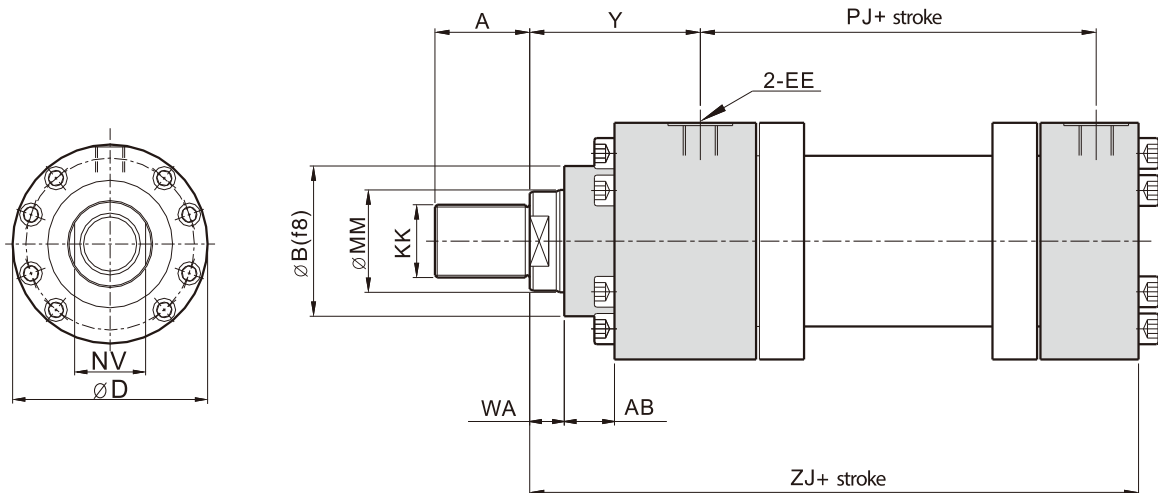

- M00(SD) double rod(basic)

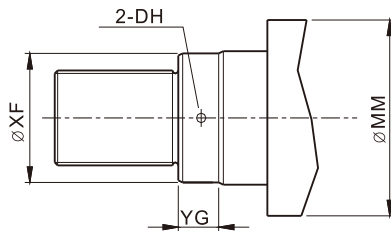
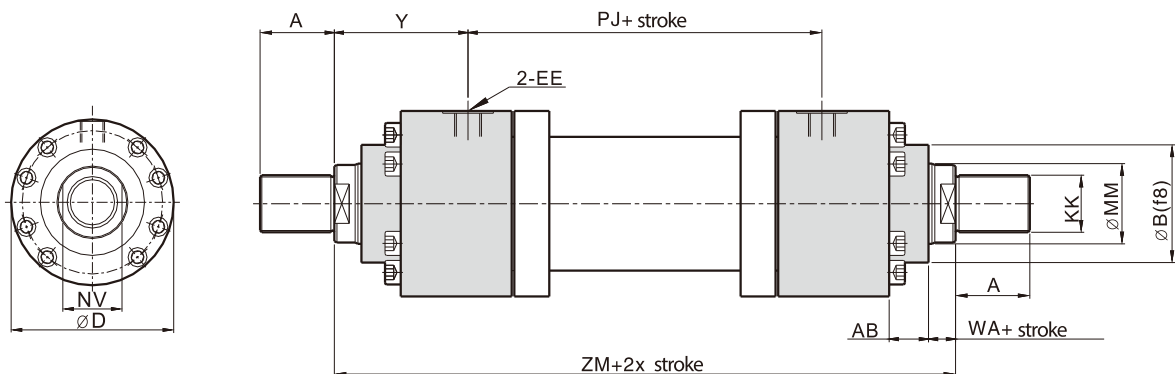

bore ≥ 80mm

Symbol bore	MM		XF		DH		YG	
	C	B	C	B	C	B	C	B
125	80	90	77	87	10	10	20	
160	100	110	96	106	10	12	25	
200	125	140	121	136	12	12	30	
250	160	180	155	175	12	12	30	
320	200	220	195	214	14	14	35	

bore	MM		KK	EE	B	ZJ	D	A	Y	PJ	WA	AB	NV	ZM
	C	B												
50	32	36	M27x2	RC1/2	63	244	108	36	98	120	18	29	32	316
63	40	45	M33x2	RC3/4	75	274	124	45	112	133	21	32	34	357
80	50	56	M42x2	RC3/4	90	305	148	56	120	155	24	36	46	395
100	63	70	M48x2	RC1	110	340	175	63	134	171	27	41	60	439
125	80	90	M64x3	RC1	132	396	208	85	153	205	31	45	-	511
160	100	110	M80x3	RC1 1/4	160	460	270	95	185	235	35	50	-	605
200	125	140	M100x3	RC1 1/4	200	550	330	112	220	278	40	61	-	718
250	160	180	M125x4	RC1 1/2	250	650	412	125	260	325	42	71	-	840
320	200	220	M160x4	RC2	320	760	510	160	310	350	48	88	-	955

## EXTERNAL DIMENSIONS

- MF3(FA) double acting(rod flange)(round)

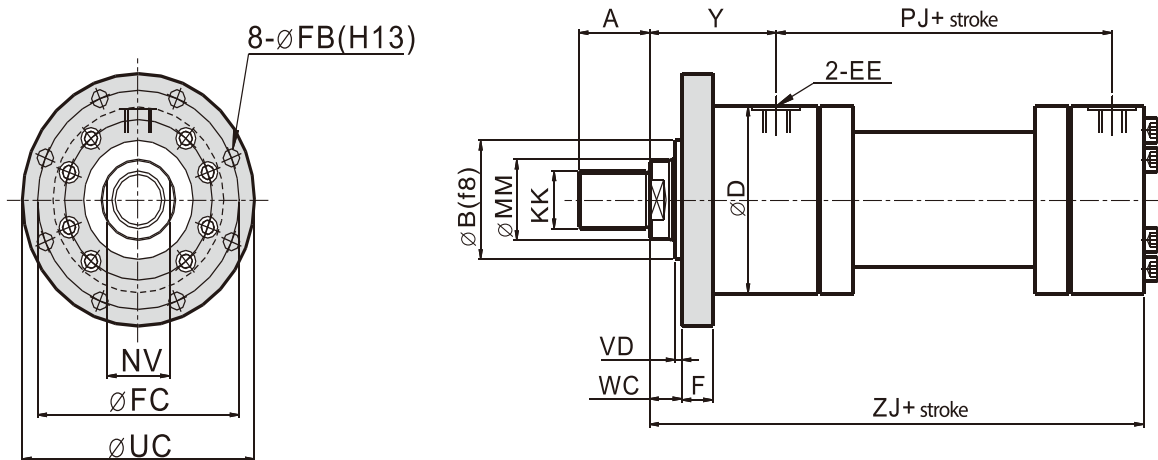

- MF3(FA) double rods(rod flange)(round)

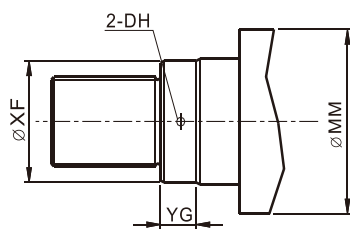
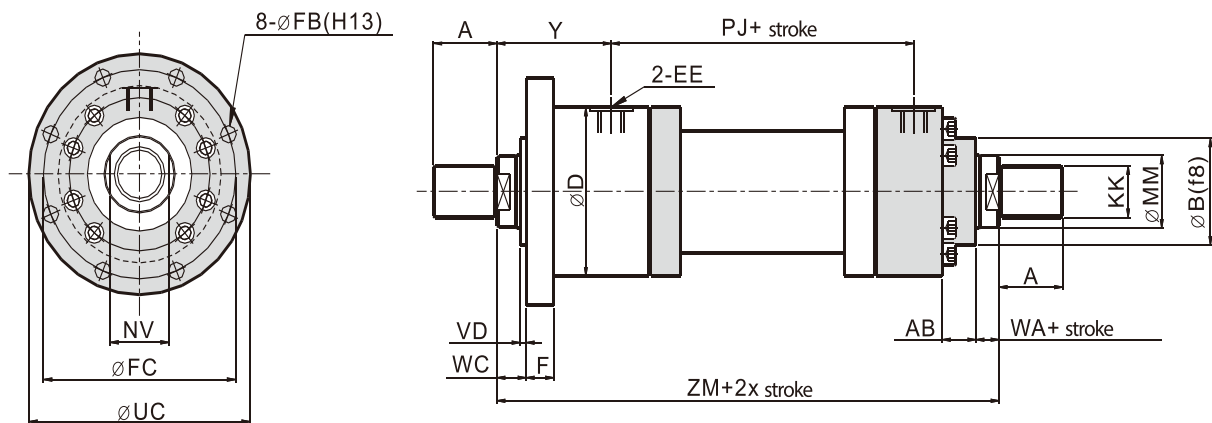

bore ≥ 80mm

symbol bore	MM		XF		DH		YG	
	C	B	C	B	C	B	C	B
125	80	90	77	87	10	10		20
160	100	110	96	106	10	12		25
200	125	140	121	136	12	12		30
250	160	180	155	175	12	12		30
320	200	220	195	214	14	14		35

bore	MM		KK	EE	A	AB	B	D	F	FB	Y	NV	VD	WA	WC	FC	UC	ZJ	PJ	ZM
	C	B																		
50	32	36	M27x2	RC1/2	36	29	63	108	25	14	98	32	4	18	22	132	155	244	120	316
63	40	45	M33x2	RC3/4	45	32	75	124	28	14	112	34	4	21	25	150	175	274	133	357
80	50	56	M42x2	RC3/4	56	36	90	145	32	18	120	46	4	24	28	180	210	305	155	395
100	63	70	M48x2	RC1	63	41	110	175	36	22	134	60	5	27	32	212	250	340	171	439
125	80	90	M64x3	RC1	85	45	132	208	40	22	153	-	5	31	36	250	290	396	205	511
160	100	110	M80x3	RC1 1/4	95	50	160	270	45	26	185	-	5	35	40	315	360	460	235	605
200	125	140	M100x3	RC1 1/4	112	61	200	330	56	33	220	-	5	40	45	385	440	550	278	718
250	160	180	M125x4	RC1 1/2	125	71	250	412	63	39	260	-	8	42	50	475	540	650	325	840
320	200	220	M160x4	RC2	160	88	320	510	80	45	310	-	8	48	56	600	675	760	350	955

Tie-rod  
Hydraulic  
Cylinder

Mold  
Hydraulic  
Cylinders

Swivel &  
Clamp  
Hydraulic  
Cylinders

Booster  
Cylinders  
&  
Unclamping  
cylinders

ISO  
Specifications  
Cylinders

Round  
Hydraulic  
Cylinders

Specific  
Hydraulic  
Cylinders

Systems  
&  
Fittings

## EXTERNAL DIMENSIONS

- MF4(FB) double acting(head flange)(round)

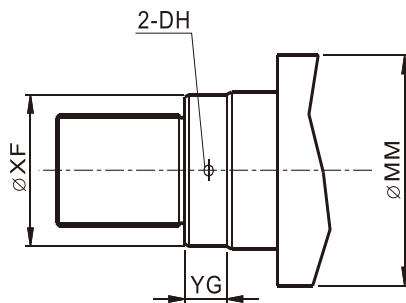
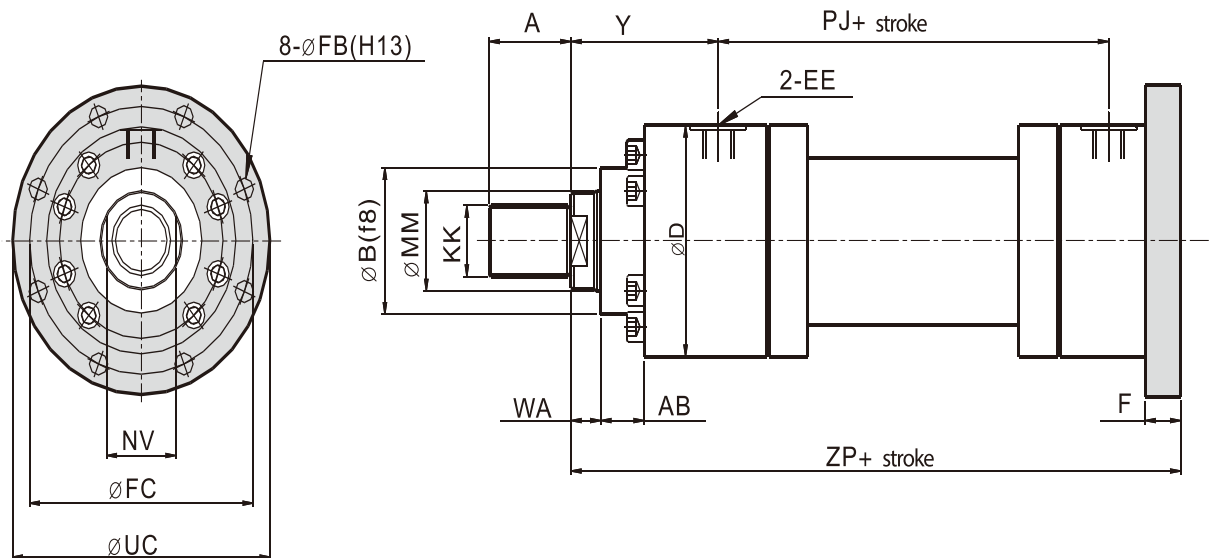

bore ≥ 80mm

symbol bore	MM		XF		DH		YG	
	C	B	C	B	C	B	C	B
125	80	90	77	87	10	10	20	
160	100	110	96	106	10	12	25	
200	125	140	121	136	12	12	30	
250	160	180	155	175	12	12	30	
320	200	220	195	214	14	14	35	

bore	MM		KK	EE	FB	B	D	F	Y	WA	AB	NV	FC	A	UC	ZP	PJ
	C	B															
50	32	36	M27x2	RC1/2	14	63	108	25	98	18	29	32	132	36	155	265	120
63	40	45	M33x2	RC3/4	14	75	124	28	112	21	32	34	150	45	175	298	133
80	50	56	M42x2	RC3/4	18	90	145	32	120	24	36	46	180	56	210	332	155
100	63	70	M48x2	RC1	22	110	175	36	134	27	41	60	212	63	250	371	171
125	80	90	M64x3	RC1	22	132	208	40	153	31	45	-	250	85	290	430	205
160	100	110	M80x3	RC1 1/4	26	160	270	45	185	35	50	-	315	95	360	505	235
200	125	140	M100x3	RC1 1/4	33	200	330	56	220	40	61	-	385	112	440	596	278
250	160	180	M125x4	RC1 1/2	39	250	412	63	260	42	71	-	475	125	540	713	325
320	200	220	M160x4	RC2	45	320	510	80	310	48	88	-	600	160	675	840	350

**EXTERNAL DIMENSIONS**

- MP3(CA) double acting(clevis)

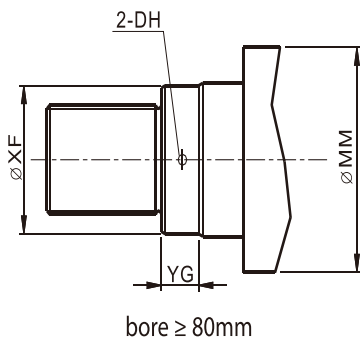
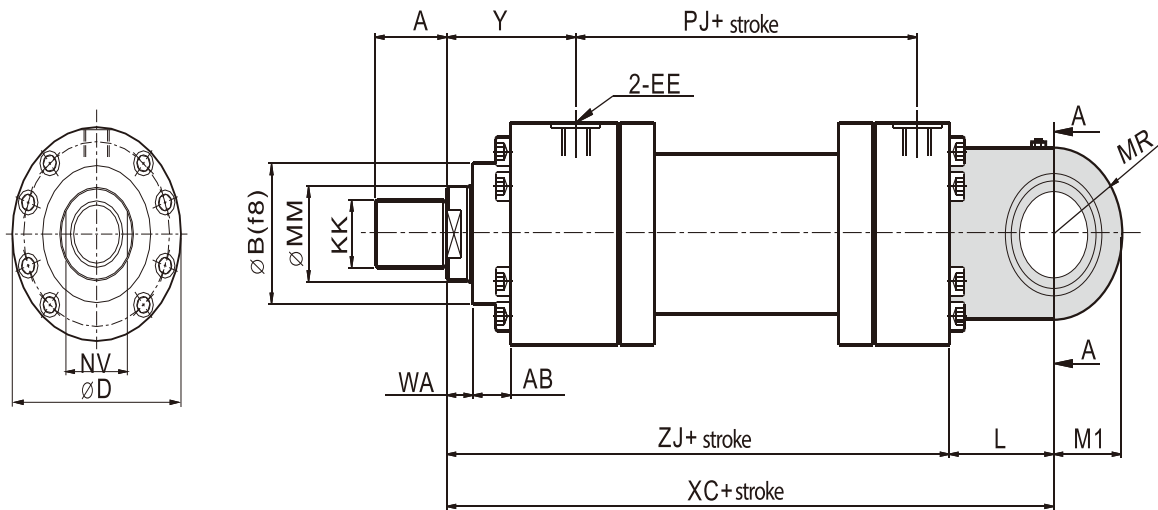

symbol bore	MM		XF		DH		YG	
	C	B	C	B	C	B	C	B
125	80	90	77	87	10	10	20	
160	100	110	96	106	10	12	25	
200	125	140	121	136	12	12	30	
250	160	180	155	175	12	12	30	
320	200	220	195	214	14	14	35	

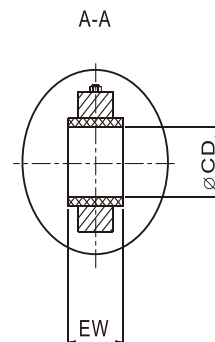

bore	MM		KK	EE	EW	B	M1	A	D	Y	WA	AB	NV	L	ZJ	PJ	XC	CD	MR
	C	B																	
50	32	36	M27x2	RC1/2	32	63	35	36	108	98	18	29	32	61	244	120	305	32	35
63	40	45	M33x2	RC3/4	40	75	50	45	124	112	21	32	34	74	274	133	348	40	50
80	50	56	M42x2	RC3/4	50	90	63	56	145	120	24	36	46	90	305	155	395	50	61.5
100	63	70	M48x2	RC1	63	110	71	63	175	134	27	41	60	102	340	171	442	63	66
125	80	90	M64x3	RC1	80	132	90	85	208	153	31	45	-	124	396	205	520	80	90
160	100	110	M80x3	RC1 1/4	100	160	112	95	270	185	35	50	-	157	460	235	617	100	118
200	125	140	M100x3	RC1 1/4	125	200	145	112	330	220	40	61	-	206	550	278	756	125	131
250	160	180	M125x4	RC1 1/2	160	250	178	125	412	260	42	71	-	253	650	325	903	160	163
320	200	220	M160x4	RC2	200	320	230	160	510	310	48	88	-	320	760	350	1080	200	209

Tie-rod Hydraulic Cylinder

Mold Hydraulic Cylinders

Swivel & Clamp Hydraulic Cylinders

Booster Cylinders & Unclamping cylinders

ISO Specifications Cylinders

Round Hydraulic Cylinders

Specific Hydraulic Cylinders

Systems & Fittings

## EXTERNAL DIMENSIONS

- MP5(CAB) double acting(clevis)(with ball bearing)

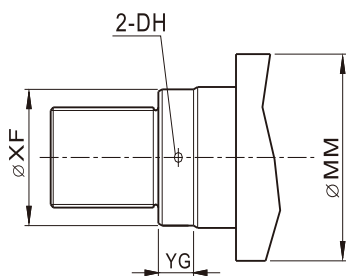
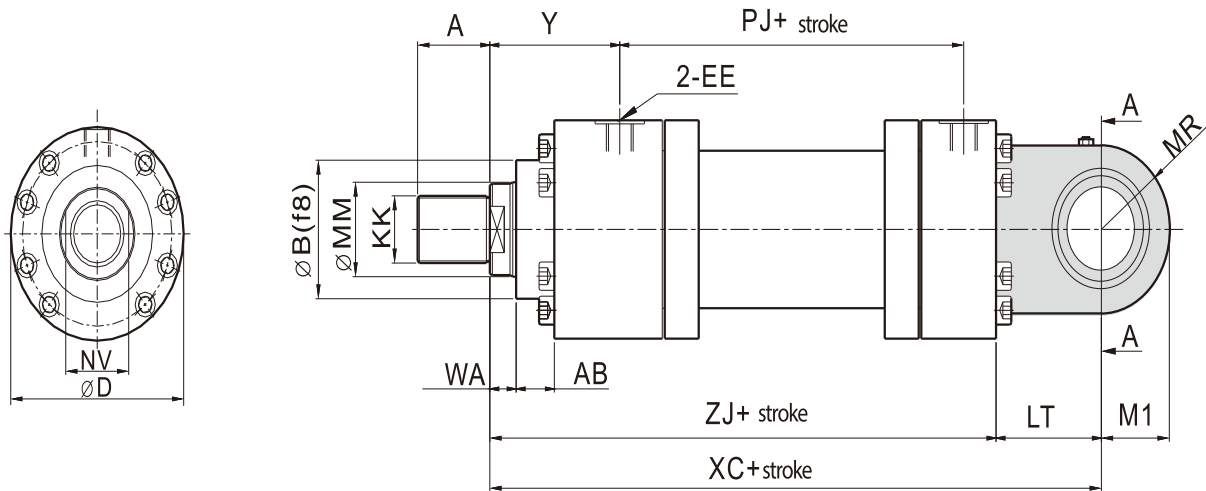

bore ≥ 80mm

symbol bore	MM		XF		DH		YG	
	C	B	C	B	C	B	C	B
125	80	90	77	87	10	10	20	
160	100	110	96	106	10	12	25	
200	125	140	121	136	12	12	30	
250	160	180	155	175	12	12	30	
320	200	220	195	214	14	14	35	

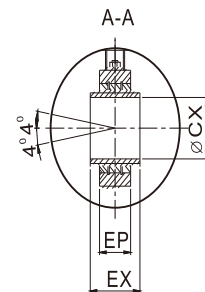

bore	MM		KK	EE	EX	EP	B	M1	A	D	Y	WA	AB	NV	LT	ZJ	PJ	XC	CX	MR
	C	B																		
50	32	36	M27x2	RC1/2	32	27	63	40	36	108	98	18	29	32	61	244	120	305	32	35
63	40	45	M33x2	RC3/4	40	35	75	50	45	124	112	21	32	34	74	274	133	348	40	50
80	50	56	M42x2	RC3/4	50	40	90	63	56	145	120	24	36	46	90	305	155	395	50	62
100	63	70	M48x2	RC1	63	52	110	71	63	175	134	27	41	60	102	340	171	442	63	66
125	80	90	M64x3	RC1	80	60	132	90	85	208	153	31	45	-	124	396	205	520	80	90
160	100	110	M80x3	RC1 1/4	100	84	160	112	95	270	185	35	50	-	157	460	235	617	100	118
200	125	140	M100x3	RC1 1/4	125	102	200	145	112	330	220	40	61	-	206	550	278	756	125	131
250	160	180	M125x4	RC1 1/2	160	130	250	178	125	412	260	42	71	-	253	650	325	903	160	163
320	200	220	M160x4	RC2	200	162	320	230	160	510	310	48	88	-	320	760	350	1080	200	209

**EXTERNAL DIMENSIONS**

- MT4(TC) double acting(mid trunnion)

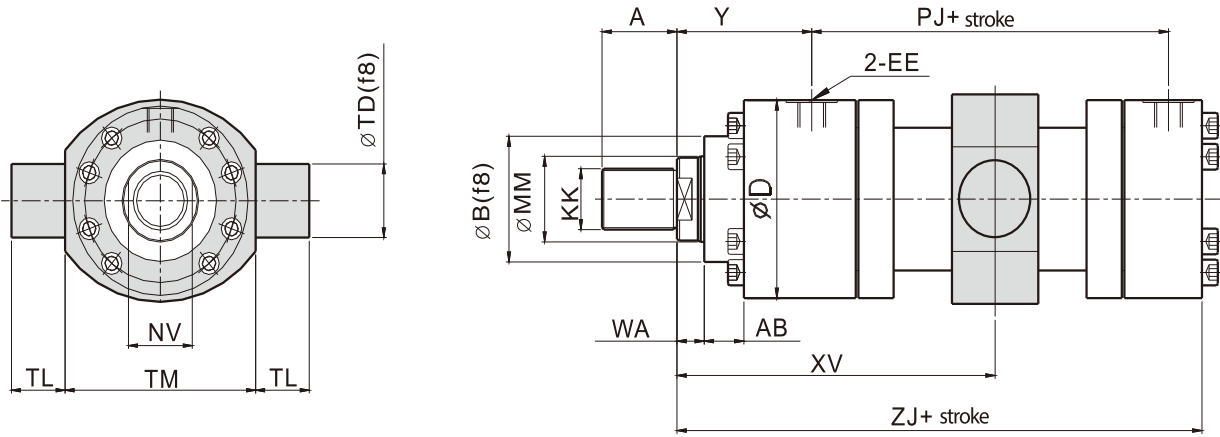

- MT4(TC) double rods(mid trunnion)

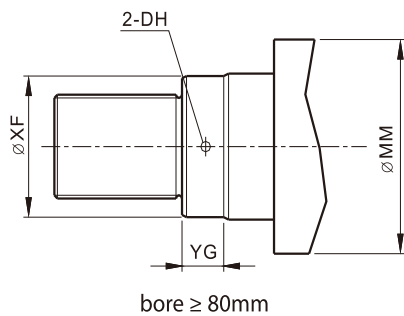
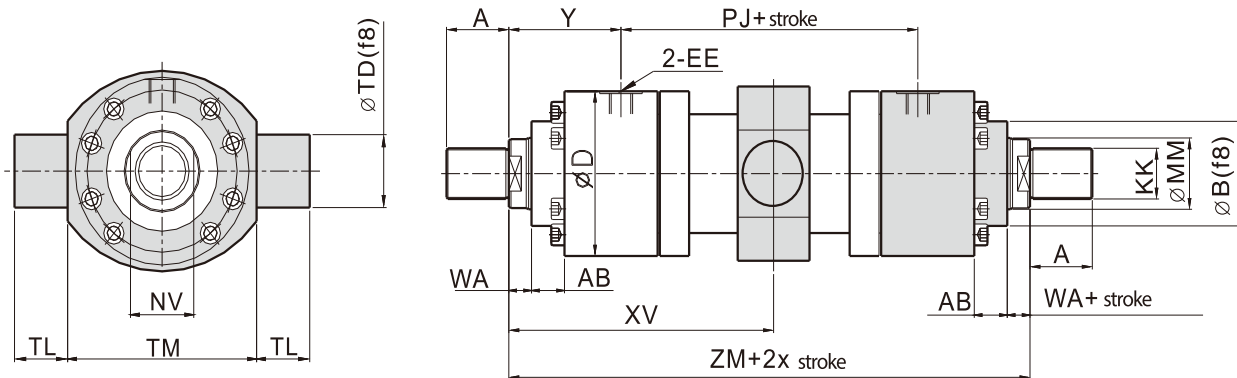

symbol	MM		XF		DH		YG	
	C	B	C	B	C	B	C	B
bore 125	80	90	77	87	10	10	20	
160	100	110	96	106	10	12	25	
200	125	140	121	136	12	12	30	
250	160	180	155	175	12	12	30	
320	200	220	195	214	14	14	35	

bore	MM		KK	EE	B	TD	ZJ	A	D	Y	WA	AB	NV	PJ	TL	TM	XV	ZM
	C	B																
50	32	36	M27x2	RC1/2	63	32	244	36	108	98	18	29	32	120	25	112	can be customized	316
63	40	45	M33x2	RC3/4	75	40	274	45	124	112	21	32	34	133	32	125		357
80	50	56	M42x2	RC3/4	90	50	305	56	145	120	24	36	46	155	40	150		395
100	63	70	M48x2	RC1	110	63	340	63	175	134	27	41	60	171	50	180		439
125	80	90	M64x3	RC1	132	80	396	85	208	153	31	45	-	205	63	224		511
160	100	110	M80x3	RC1 1/4	160	100	460	95	270	185	35	50	-	235	80	280		605
200	125	140	M100x3	RC1 1/4	200	125	550	112	330	220	40	61	-	278	100	335		718
250	160	180	M125x4	RC1 1/2	250	160	650	125	412	260	42	71	-	325	125	425		840
320	200	220	M160x4	RC2	320	200	760	160	510	310	48	88	-	350	160	530		955

Tie-rod Hydraulic Cylinder

Mold Hydraulic Cylinders

Swivel & Clamp Hydraulic Cylinders

Booster Cylinders & Unclamping cylinders

ISO Specifications Cylinders

Round Hydraulic Cylinders

Specific Hydraulic Cylinders

Systems & Fittings



## EXTERNAL DIMENSIONS

- MS2(LA) double acting (foot flange)

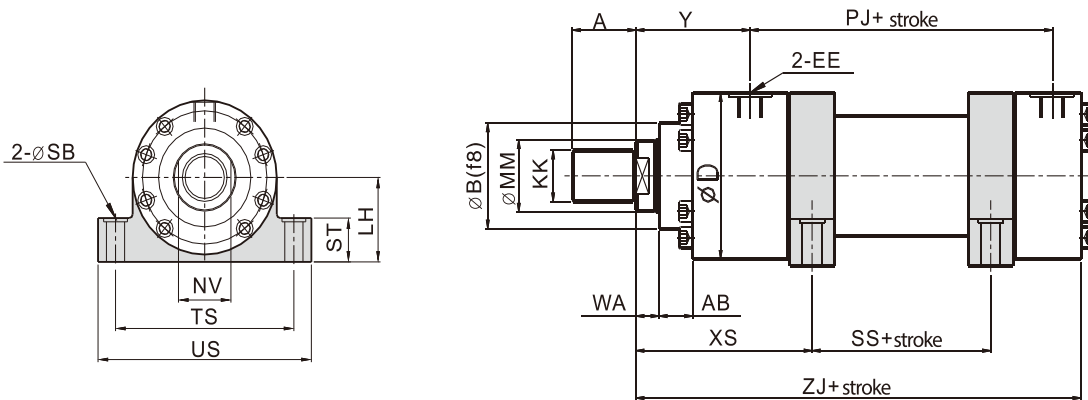

- MS2(LA) double rods (foot flange)

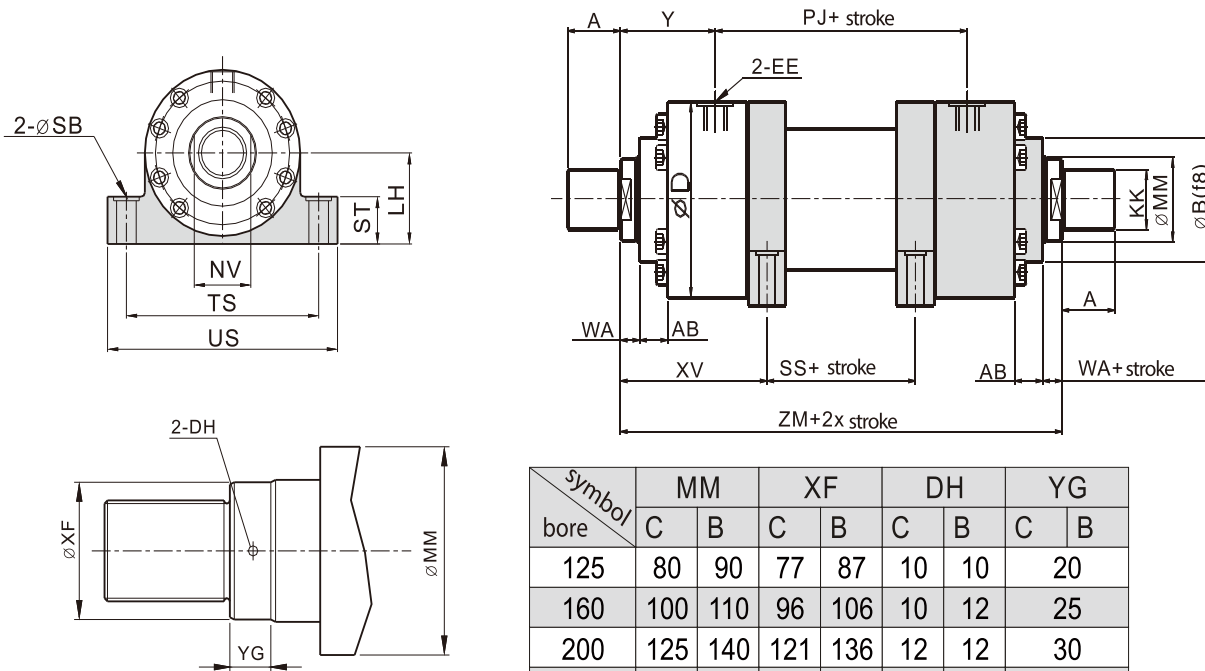

symbol	MM		XF		DH		YG	
	C	B	C	B	C	B	C	B
bore 125	80	90	77	87	10	10	20	
160	100	110	96	106	10	12	25	
200	125	140	121	136	12	12	30	
250	160	180	155	175	12	12	30	
320	200	220	195	214	14	14	35	

bore	MM		KK	EE	B	ZJ	SS	PJ	ZM	D	Y	WA	AB	NV	SB	ST	TS	US	XS	LH
	C	B																		
50	32	36	M27x2	RC1/2	63	244	55	120	316	108	98	18	29	32	11	32	135	160	130	60
63	40	45	M33x2	RC3/4	75	274	55	133	357	124	112	21	32	34	13.5	37	155	185	147.5	68
80	50	56	M42x2	RC3/4	90	305	55	155	395	148	120	24	36	46	17.5	42	185	225	170.5	80
100	63	70	M48x2	RC1	110	340	55	171	439	175	134	27	41	60	22	52	220	265	192.5	95
125	80	90	M64x3	RC1	132	396	60	205	511	208	153	31	45	-	26	62	270	325	230	115
160	100	110	M80x3	RC1 1/4	160	460	79	235	605	270	185	35	50	-	33	77	340	405	265.5	145
200	125	140	M100x3	RC1 1/4	200	550	90	278	718	330	220	40	61	-	40	87	405	480	315	170
250	160	180	M125x4	RC1 1/2	250	650	120	325	840	412	260	42	71	-	52	112	520	620	360	215
320	200	220	M160x4	RC2	320	760	120	350	955	510	310	48	88	-	62	152	620	740	425	260