

SQUARE AUTO-LOCKING CYLINDERS JEAL-S



- Integrate mechanical lock and automatic lock, avoiding the use of auxiliary lock.
- Compact structure, high clamping force.
- All the seals adopt the specifications from well-known foreign brands, seal performance is good.
- Optional inductive proximity switch, cylinder action will be more accurate.
- Installation size compatible with French brands.

FEATURE

Bore	32、40、50、80
Mineral oil	Mineral oil (ISO-VG32)
Working pressure	160kgf/cm ² (16MPa)
Working temperature	-10°C ~+200°C
Piston speed	Max 1m/s
Filtering criteria	NAS 7-9 or better

THEORETICAL FORCE

Bore (mm)	Shaft (mm)	Piston pressure area(c m ²)		theoretical force (P=160kgf/c m ²)		theoretical force (P=210kgf/c m ²)	
		Push	Pull	Push	Pull	Push	Pull
32	22	8.04	5.5	1286	880	1688	1155
40	28	12.56	8.04	2010	1286	2638	1688
50	36	19.63	12.56	3141	2010	4122	2638
80	56	50.24	30.62	8038	4899	10550	6430

SEAL MATERIAL

Material Symbol	(NBR)	(PU)	(FPM)
Oil	1	2	3
Mineral	O	O	O
Water solution	O	X	O
Soluble	O	X	O
phosphate ester	X	X	O
Temperature	-20°C ~ +80°C		-10°C ~ +200°C
Viscosity	20~400mm ² /s { cst }		



Note:

- 1、 mineral oil: ISO-VG32。
- 2、 If mineral oil is used, there is no need to mark it. Our company will provide standard oil seal (NBR).
- 3、 If phosphate ester oil is used or high temperature is applied, will shown as symbol 3.
- 4、 symbol O = ok, x = cannot be used.
- 5、 Temperature of FPM must set below 150 °C when operate long time.

WORKING PRINCIPLE OF CYLINDER

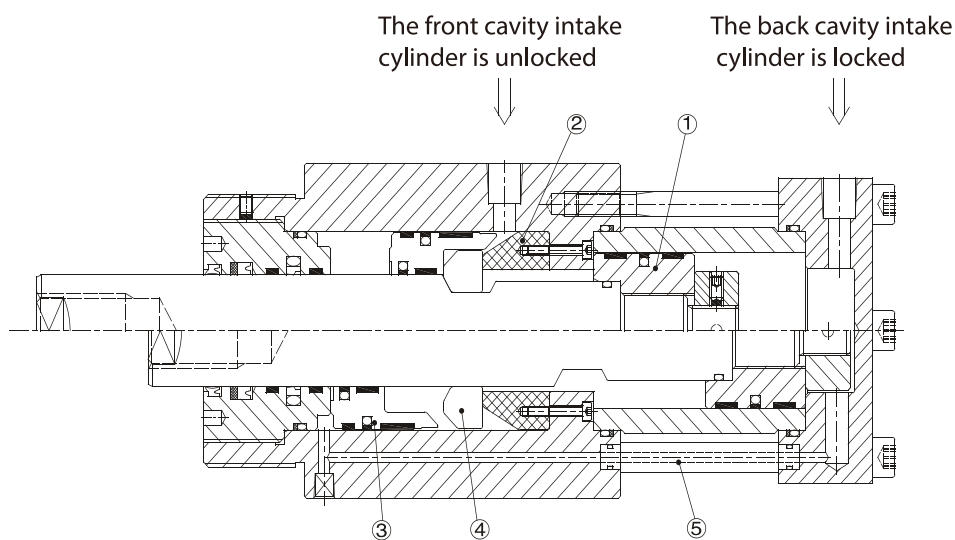

The oil inlet of the back cover is fed, and the oil pushes the press block ③ through the oil inlet pipe ⑤ to tighten the self-locking block ④, while the oil pushes the piston ① forward. When the piston ① completes the stroke, the self-locking block ④ falls into the groove of the piston rod under the push of the press block ③, at this time the self-locking block ④ is locked in the radial and axial direction, the piston rod is also completely locked, and the cylinder is in a self-locking state, even if the oil pressure is removed, the piston rod will not receded. The oil inlet of the front cover is fed, the oil pushes the press block ③ forward, and pushes the piston ① back, and the self-locking block ④ returns to the initial position, at which time the cylinder is in the unlocked state.

Tie-rod Hydraulic Cylinder

Mold Hydraulic Cylinders

Swivel & Clamp Hydraulic Cylinders

Booster Cylinders & Unclamping cylinders

ISO Specifications Cylinders

Round Hydraulic Cylinders

Specific Hydraulic Cylinders

Systems & Fittings

ORDER INDICATION

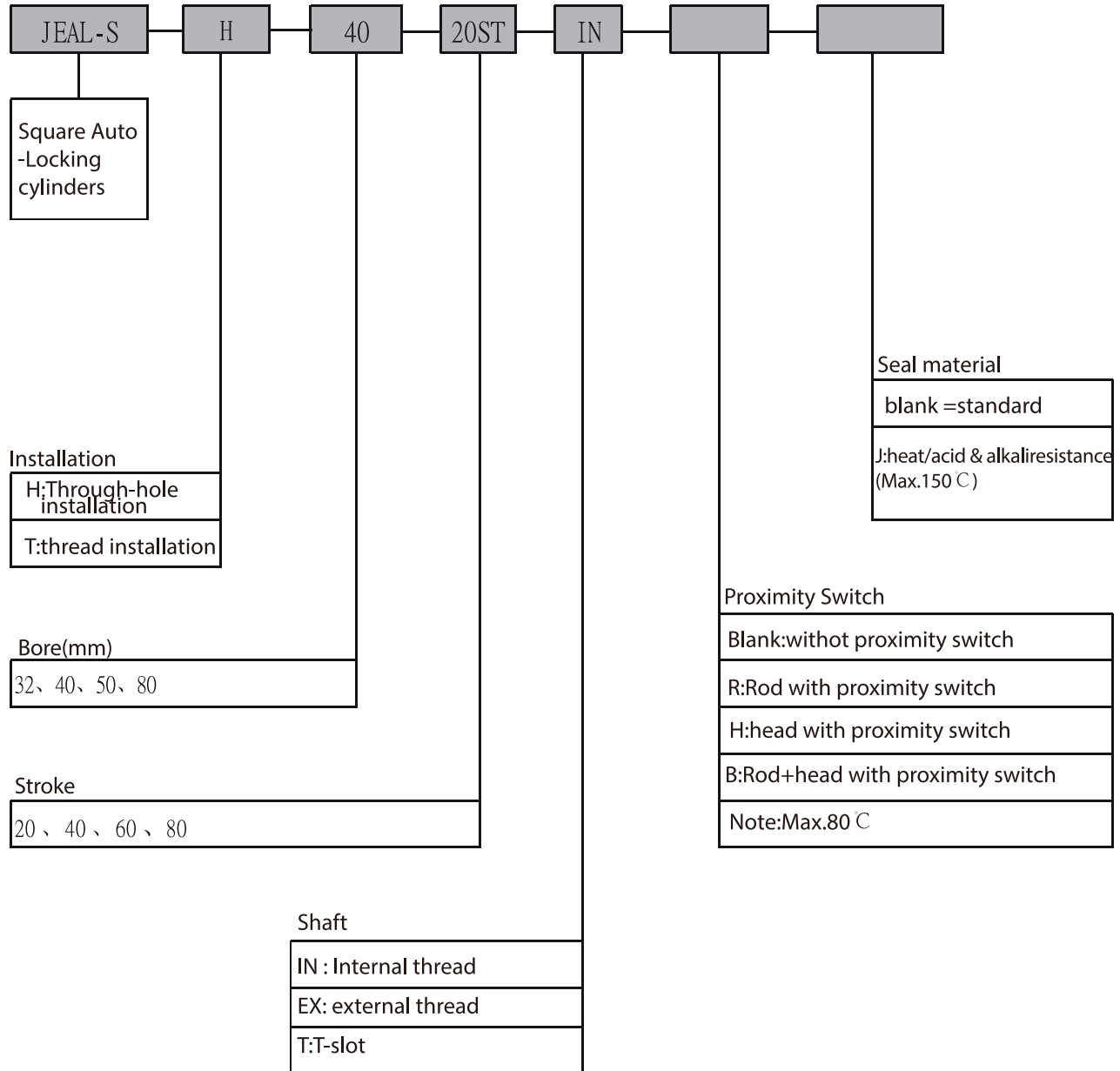

**INTERNAL STRUCTURE
AND PART NAMES**

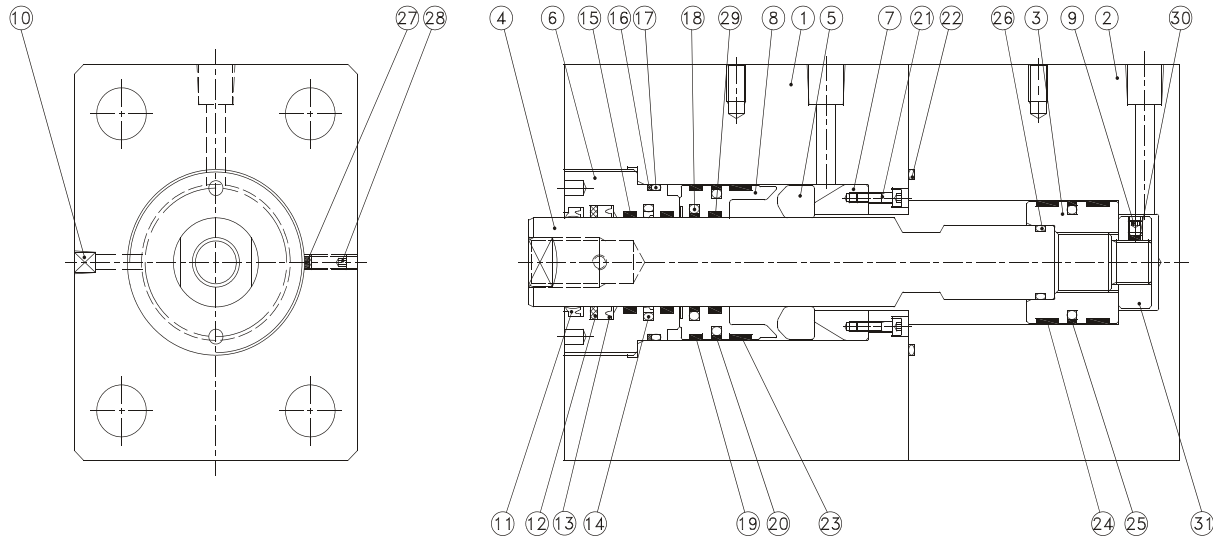

Tie-rod
Hydraulic
Cylinder

Mold
Hydraulic
Cylinders

Swivel &
Clamp
Hydraulic
Cylinders

Booster
Cylinders
&
Unclamping
cylinders

ISO
Specifications
Cylinders

Round
Hydraulic
Cylinders

Specific
Hydraulic
Cylinders

Systems
&
Fittings

item	part name	qty	item	part name	qty	item	part name	qty	item	part name	qty
①	Rod cover	1	⑨	set screw	1	⑰	Seal O ring	1	⑳	Piston flat seal	1
②	Head cover	1	⑩	Throat plug	1	⑱	Block flat seal	1	㉑	Rod O ring	1
③	Piston	1	⑪	Dust seal	1	㉒	Block wear ring	2	㉒	Copper gasket	1
④	Rod	1	⑫	Backup ring	1	㉓	Block flat seal	1	㉓	set screw	1
⑤	Self-locking block	1	⑬	U seal	1	㉔	Internal hexagonal steel screw	4	㉔	Block wear ring	1
⑥	Bush	1	⑭	Bush flat seal	1	㉕	O ring	1	㉕	Copper gasket	1
⑦	Stop block	1	⑮	Wear ring	2	㉖	Block wear ring	1	㉖	Inductive block	1
⑧	Block	1	⑯	bush.back-up ring	1	㉗	piston wear ring	2			

SEAL SPEC.

Item	⑪	⑫	⑬	⑭	⑮	⑯	⑰	⑱	⑲
Name	Dust seal	Back-up ring	U seal	bush flat seal	wear ring /joint	bush back-up ring	bush O ring	Block flat seal	Block wear ring
Bore qty	1	1	1	1	2/1	1	1	1	1
32	22x30x6	22x30x2	22x30x5	22x32.7x3.2	MB2208DU	40x45x1.25	G40	22x32.7x4.2	45x50x5.6
40	28x36x6	28x36x3	28x36x5	28x38.7x3.2	MB2810DU	55x60x1.25	G55	28x38.7x4.2	58x63x5.6
50	36x44x6.5	36x46x3	36x46x6	36x46.7x4.2	36x41x5.6	60x65x1.25	G60	36x46.7x4.2	58x63x5.6
80	56x64x6.5	56x66x3	56x66x6	56x71.1x6.3	56x61x9.7	90x95x1.25	G90	56x71.1x6.3	95x100x9.7

Item	⑳	㉑	㉒	㉓	㉔	㉕	㉖	㉗
Name	Block flat seal	O ring	Block wear ring	piston wear ring	Piston flat seal	Rod O ring	Block wear ring	
Bore qty	1	1	1	2	1	1	1	
32	39x50x4.2	G40	45x50x5.6	27x32x5.6	24.5x32x3.2	P14	22x27x5.6	
40	52x63x4.2	G55	58x63x9.7	35x40x5.6	29x40x4.2	P20	28x33x5.6	
50	52x63x4.2	G60	58x63x9.7	45x50x9.7	39x50x4.2	G25	36x41x5.6	
80	89x100x4.2	G90	95x100x15	75x80x15	69x80x4.2	G45	56x61x9.7	

TYPE OF PISTON ROD SHAFT END

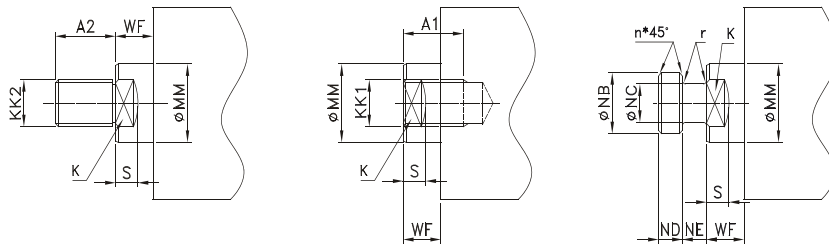

IN:Internal thread

EX:External thread

T:T-slot

Symbol	MM	K	KK1	KK2	NB	A1	NC	ND	NE	n	r	S	WF	A2
Bore 32	22	17	M12	M12	18	15	10	8	8	1	1	10	15	20
40	28	22	M16	M16	22	25	14	10	10	1	1	12	15	25
50	36	30	M20	M20	28	30	18	13	13	2	2	12	15	30
80	56	46	M30	M30	45	50	28	20	20	2	2	15	19	50

EXTERNAL DIMENSIONS

● JEAL-S-H Through-hole installation

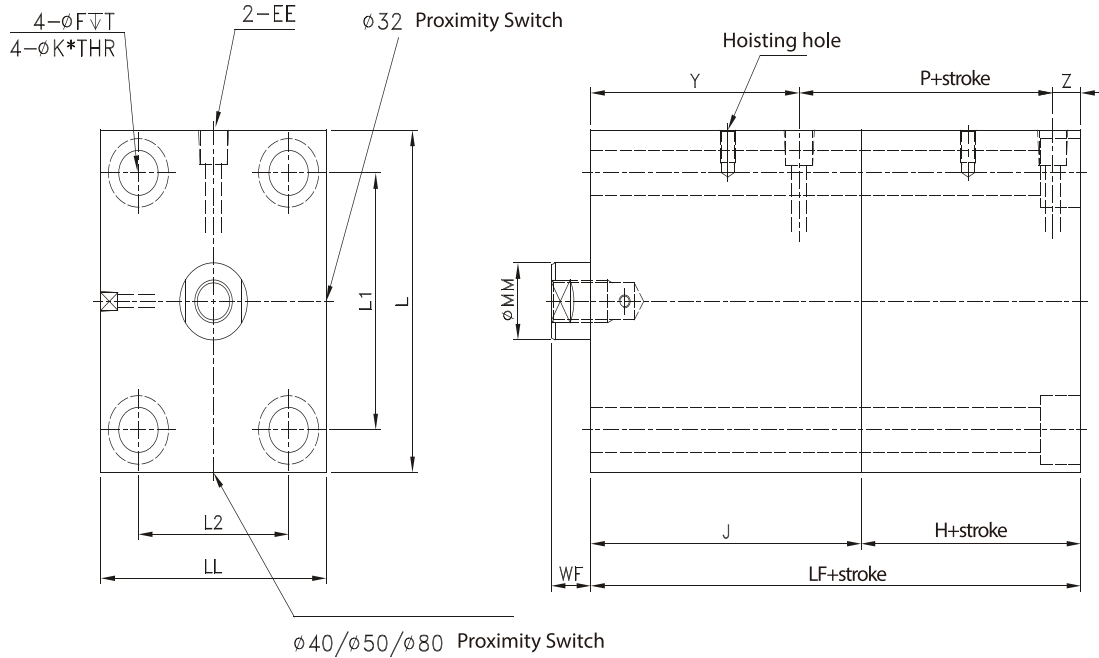

Symbol Bore	MM	Y	Z	P	WF	J	H	LF	EE	F	T	L2	L	LL	L1	K
32	22	90	10	70	15	120	50	170	RC1/4	19	13	40	85	63	63	13
40	28	101	11	78	15	135	55	190	RC1/4	26	18	65	125	95	95	17
50	36	111	15	85	15	146	65	211	RC3/8	32	22	80	160	120	120	21
80	56	151	17	107.5	19	191	84.5	275.5	RC1/2	42	29	108	200	150	158	29

- ⚠ Note: ✘ Standard stroke:20,40,60,80
 ✘ The body size is shared with EX/T.
 ✘ Reserves the right to change technology.

- Tie-rod Hydraulic Cylinder
- Mold Hydraulic Cylinders
- Swivel & Clamp Hydraulic Cylinders
- Booster Cylinders & Unclamping cylinders
- ISO Specifications Cylinders
- Round Hydraulic Cylinders
- Specific Hydraulic Cylinders
- Systems & Fittings

EXTERNAL DIMENSIONS

● JEAL-S-T Thread installation

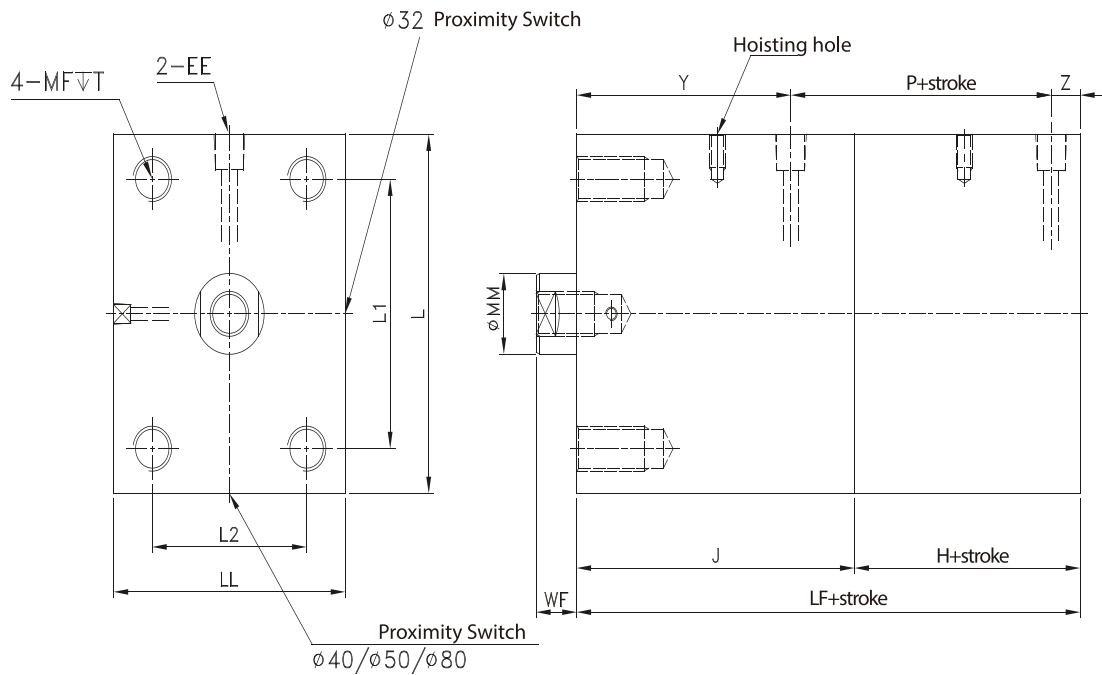

Symbol	MM	Y	Z	P	WF	J	H	LF	EE	MF	T	L2	L	LL	L1
Bore 32	22	90	10	70	15	120	50	170	RC1/4	M12	24	40	85	63	63
40	28	101	11	78	15	135	55	190	RC1/4	M16	32	65	125	95	95
50	36	111	15	85	15	146	65	211	RC3/8	M20	35	80	160	120	120
80	56	151	17	107.5	19	191	84.5	275.5	RC1/2	M27	50	108	200	150	158

- ⚠ Note:
- ✘ Standard stroke:20,40,60,80
 - ✘ The body size is shared with EX/T.
 - ✘ Reserves the right to change technology.

INDUCTIVE PROXIMITY SWITCH

● BES 516-300-S



PROXIMITY SWITCH PARAMETER

PNP Proximity Switch Parameter	
Rated sensing distance S_n	1.5mm
Reliable induction distance S_a	0~1.2mm
Supply voltage U_B	10~30V DC
Repeated positioning accuracy R	$\leq 5\%$
Rated working current I_e	200mA
Switch operating frequency f	2000HZ
Polar reverse protection	Yes
temperature range T_a	-25~+80°C
Straight plug type	BKS-S 20
Withstand high voltage	500 bar
Protection class	Ip68 complies with BWN Pr.20

Tie-rod Hydraulic Cylinder

Mold Hydraulic Cylinders

Swivel & Clamp Hydraulic Cylinders

Booster Cylinders & Unclamping cylinders

ISO Specifications Cylinders

Round Hydraulic Cylinders

Specific Hydraulic Cylinders

Systems & Fittings