

**MGHC TIE ROD CYLINDER FOR MAGNETIC SENSORS**

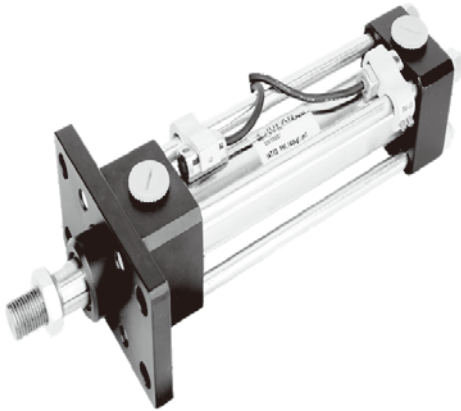
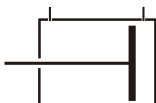
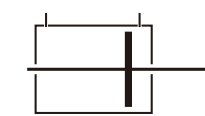
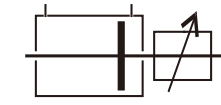

- Magnet sensor can be attached as position signal transmission
- Adopt four-position tie rod structure design, versatile and easy to maintain
- Designed and manufactured according to Japan standard specifications JIS-B8367
- Multiple installation options available
- Use stainless steel pipe
- Piston with magnet

**TYPE**

Type	Mark	Graphics	Heat/acid & alkali resistance	Dust cover	Inner diameter (mm)
Double acting cylinder	MGHC1-A		MGHC1-AJ	MGHC1-AH	32,40,50 63,80,100 125,150
Biaxial cylinder	MGHC1-C		MGHC1-CJ	MGHC1-CH	
Double acting cylinder with adjustable stroke	MGHC1-D		MGHC1-DJ	MGHC1-DH	

**INSTALLATION FORM**

Mark	Type	Graphics	Mark	Type	Graphics
SD	Basic		LA	Foot flange	
FA	Rod Flange		LB	End flange	
FB	Head Flange		TA	Rod Trunnion	
CA	Clevis		TC	Mid Trunnion	
CB	Dual Clevis				

**SEAL MATERIAL**

material symbol	material		
	(NBR)	(FPM)	(PU)
oil	standard	J	-
mineral	O	O	O
water solution	O	O	X
soluble	O	O	X
phosphate ester	X	O	X
temperature	-10°C~+80°C	-10°C~+150°C	-10°C~+80°C
viscosity	20~400mm <sup>2</sup> /s {cSt}		

Note:

- 1.mineral oil : ISO-VG32
- 2.If mineral oil is used,NBR will be used without specify selections of material.
- 3.If phosphate ester oil is used or high temperature is applied, will shown as symbol J.
- 4.symbol O = ok, X = cannot be used.
- 5.Temperature of FPM must set below 150°C when operate long time.

Tie-rod Hydraulic Cylinder

Mold Hydraulic Cylinders

Swivel & Clamp Hydraulic Cylinders

Booster Cylinders & Unclamping cylinders

ISO Specifications Cylinders

Round Hydraulic Cylinders

Specific Hydraulic Cylinders

Systems & Fittings

**PORT AND CUSHION POSITIONS**

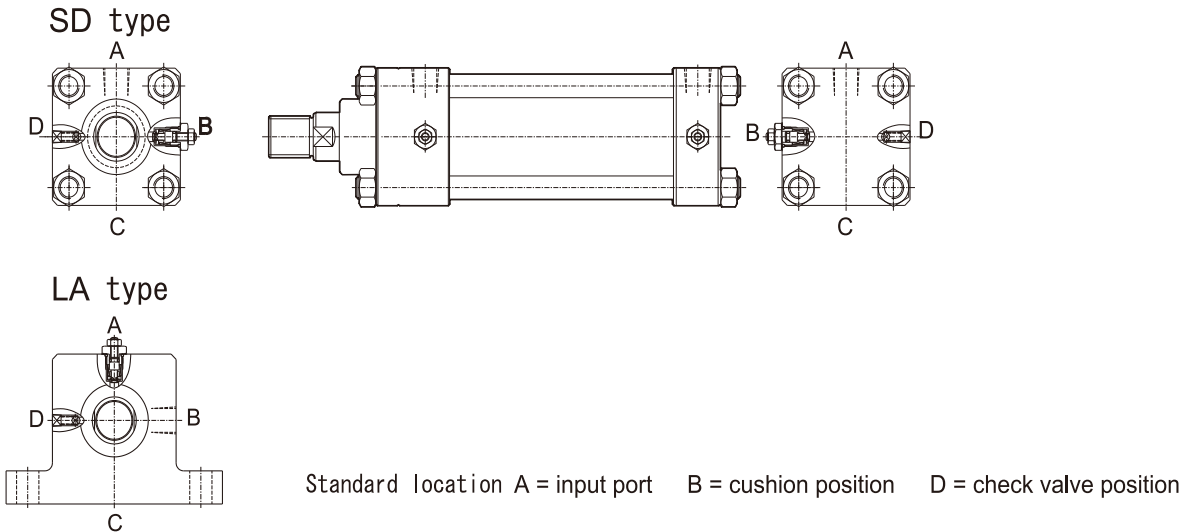

**USE OF CUSHION VALVES**

■ Alignment steps

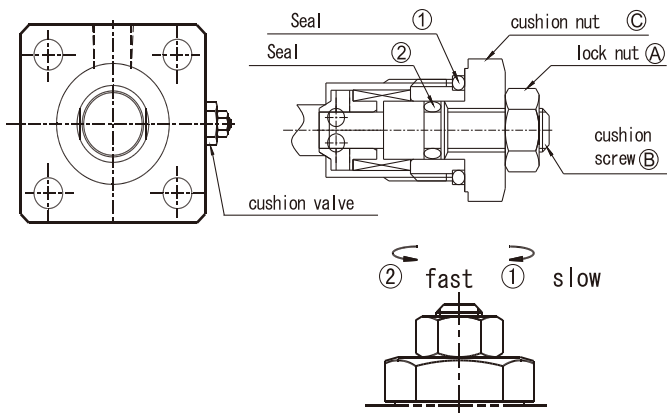

1. Turn lock nut (A) toward counter clockwise with 1/4 circle by wrench.
2. Use wrench to lock cushion nut (C) tightly to prevent ① ② oil spill.
3. Use screwdriver to adjust speed of (B)
  - ① clockwise: rod speed will slow down
  - ② counter clockwise: rod speed will increase
4. After alignment, fix (B) with hex wrench then tighten (A)

Note: Loose lock nut (A) before adjust (B).

**BUFFER LENGTH**

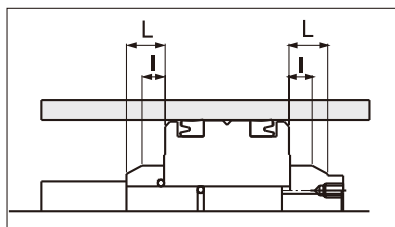

inner diameter (mm)	Buffer length (front)		Buffer length (rear)	
	L	I	L	I
32	15	12	18	15
40~63	20	15	20	15
80~100	25	20	25	20
125	30	25	30	25
150~224	35	30	35	30
250	40	30	33	28

1. Buffering is required when the action speed of the cylinder reaches 100mm/s after the load is applied.
2. When the action speed is greater than 200mm/s, an external buffer should be considered.

**INTERNAL STRUCTURE AND PART NAMES**

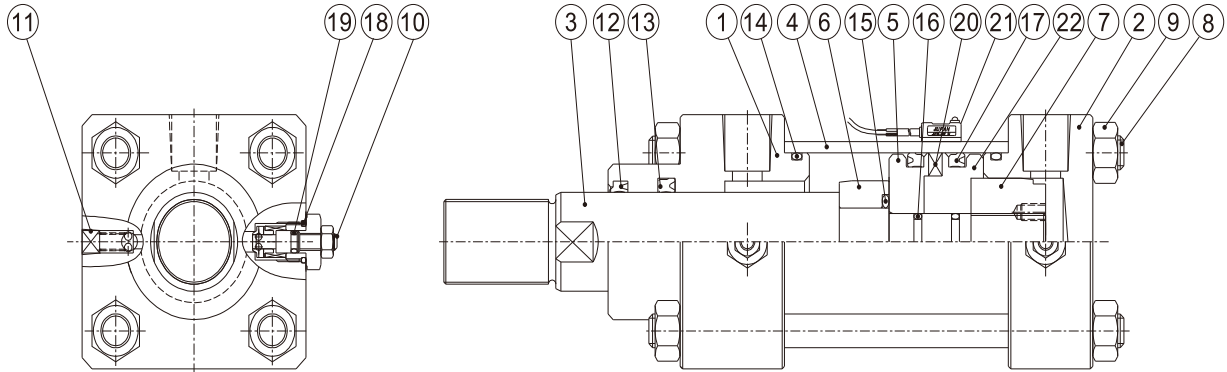

item	part name	qty	item	part name	qty
①	rod cover	1	⑫	rod dust seal	1
②	head cover	1	⑬	rod seal	1
③	piston rod	1	⑭	cover O ring	2
④	tube	1	⑮	cushion O ring	1
⑤	rod piston	1	⑯	piston O ring	2
⑥	rod cushion	1	⑰	piston packing	2
⑦	head cushion	1	⑱	valve O ring	2
⑧	tie-rod	4	⑲	valve O ring	2
⑨	tie-rod nut	8	⑳	induction magnet	1
⑩	cushion aligning valve	2	㉑	magnetic sensor	2
⑪	check and vent valve	2	㉒	end piston	1

- Tie-rod Hydraulic Cylinder
- Mold Hydraulic Cylinders
- Swivel & Clamp Hydraulic Cylinders
- Booster Cylinders & Unclamping cylinders
- ISO Specifications Cylinders
- Round Hydraulic Cylinders
- Specific Hydraulic Cylinders
- Systems & Fittings

**ORDER INDICATION**

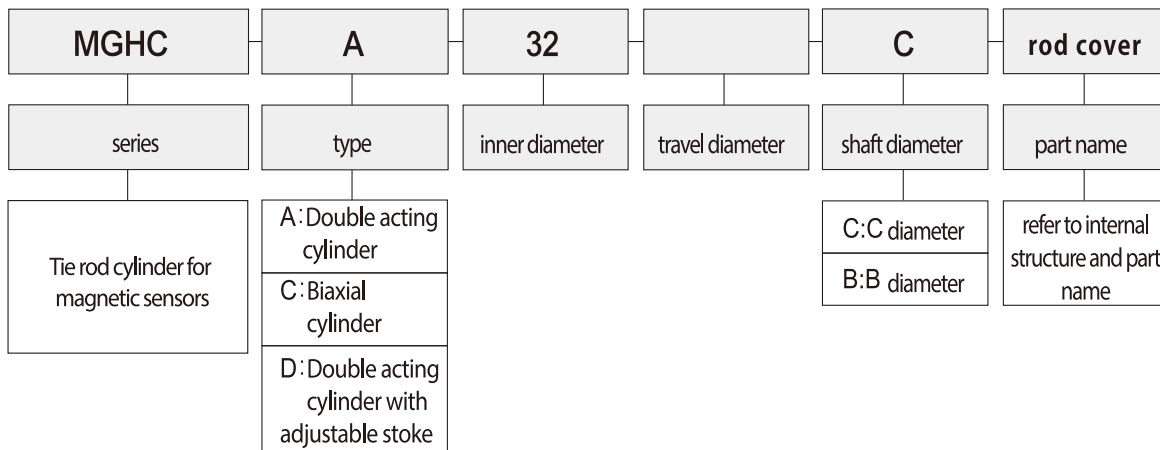

**SEAL SPEC.**

bore	item	⑫	⑬	⑭	⑮	⑯	⑰	⑱	⑲
		rod dust seal (NBR)	rod seal (NBR)	cover O ring (1B)	cushion O ring (1B)	piston O ring (1B)	piston packing (NBR)	valve O ring (1A)	valve O ring (1A)
		1	1	2	1	2	2	2	2
32	C	16×24×6	16×24×5	G25 cushioning SM32	SM12.5	AP10A	24×32×5	P11	P5
	B	20×28×6	20×28×5						
40	C	20×28×6	20×28×5	G35 cushioning SM40	P14	AP10A	30×40×6	P11	P5
	B	25×33×6	25×33×5						
50	C	25×33×6	25×33×5	G45	P18	P14	40×50×6	P11	P5
	B	30×38×6.5	30×40×6						
63	C	30×38×6.5	30×40×6	G58	P24	P20	53×63×6	P11	P5
	B	35×43×6.5	35×45×6						
80	C	35×43×6.5	35×45×6	G75	G30	G25	70×80×6	P11	P5
	B	40×48×6.5	40×50×6						
100	C	40×48×6.5	40×50×6	G95	G35	G30	85×100×9	P11	P5
	B	56×64×6.5	56×66×6						
125	C	56×64×6.5	56×66×6	G120	G50	G45	112×125×9	P14	P6
	B	70×80×8	70×80×6						
150	C	65×73×6.5	65×75×6	G145	G55	G50	136×150×8.5	P14	P6
	B	85×95×8	85×100×9						

**ORDER INDICATION**

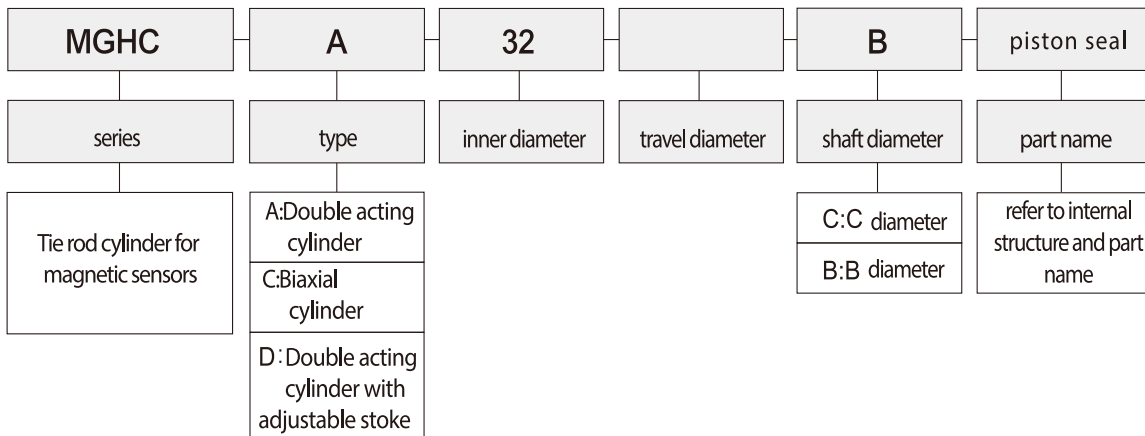

HC70/140 CONNECTOR

● Y connector

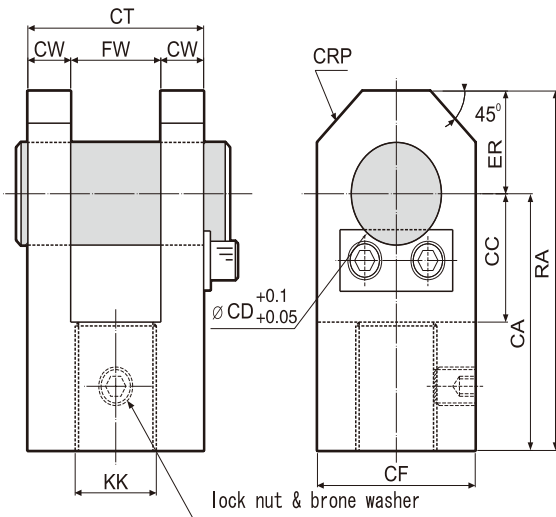

● I connector

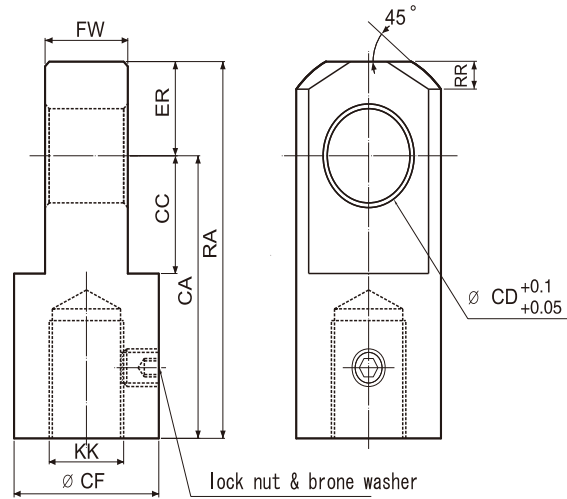

Tie-rod Hydraulic Cylinder

Mold Hydraulic Cylinders

Swivel & Clamp Hydraulic Cylinders

Booster Cylinders & Unclamping cylinders

ISO Specifications Cylinders

Round Hydraulic Cylinders

Specific Hydraulic Cylinders

Systems & Fittings

symbol bore	KK		FW		CA		RA		CF		CD	CT	CC		ER	CW	RP	RR
	rod C	rod B	Y	I	Y	I	Y	I	Y	I			Y	I				
32	M12xP1.5	M16xP1.5	20 <sup>+0.40</sup> <sub>+0.10</sub>	20 <sup>-0.10</sup> <sub>-0.40</sub>	49	69	65	85	32	38	16	45	24	24	16	12.5	8	8
40	M16xP1.5	M20xP1.5	20 <sup>+0.40</sup> <sub>+0.10</sub>	20 <sup>-0.10</sup> <sub>-0.40</sub>	49	69	65	85	32	38	16	45	24	24	16	12.5	8	8
50	M20xP1.5	M24xP1.5	25 <sup>+0.40</sup> <sub>+0.10</sub>	25 <sup>-0.10</sup> <sub>-0.40</sub>	60	80	80	100	40	45	20	55	35	30	20	15	10	10
63	M24xP1.5	M30xP1.5	30 <sup>+0.40</sup> <sub>+0.10</sub>	30 <sup>-0.10</sup> <sub>-0.40</sub>	75	105	105	135	60	60	31.5	63	40	45	30	16.5	15	15
80	M30xP1.5	M36xP1.5	30 <sup>+0.40</sup> <sub>+0.10</sub>	30 <sup>-0.10</sup> <sub>-0.40</sub>	75	105	105	135	60	60	31.5	63	40	45	30	16.5	15	15
100	M36xP1.5	M48xP1.5	40 <sup>+0.40</sup> <sub>+0.10</sub>	40 <sup>-0.10</sup> <sub>-0.40</sub>	100	120	140	160	70	70	40	78	50	50	40	19	20	20
125	M48xP1.5	M64xP2.0	63 <sup>+0.40</sup> <sub>+0.10</sub>	63 <sup>-0.10</sup> <sub>-0.40</sub>	180	180	230	230	100	100	50	126	70	65	50	31.5	25	25
150	M60xP2.0	M76xP2.0	80 <sup>+0.60</sup> <sub>+0.10</sub>	80 <sup>-0.10</sup> <sub>-0.60</sub>	225	225	290	290	120	120	63	160	90	85	65	40	32	32

ORDER INDICATION

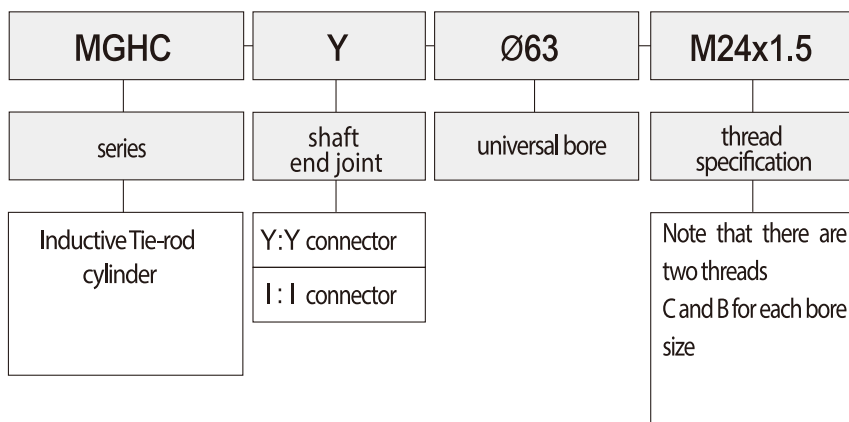

## ROD NUT

bore: 32~100

	KK	B	C	H
M12xP1.5	19	22	8	
M16xP1.5	24	27	10	
M20xP1.5	30	34	11	
M24xP1.5	36	41	13	
M30xP1.5	41	47	17	
M36xP1.5	50	57	18	
M39xP1.5	50	57	18	

bore: 100~150

	KK	DD	H	S	T
M48xP1.5	70	18	6	2.5	
M60xP2.0	90	20	7	3	
M64xP2.0	95	20	7	3	
M72xP2.0	105	25	8	3.5	
M76xP2.0	110	30	8	3.5	

## NOTES OF TIE ROD ASSEMBLY

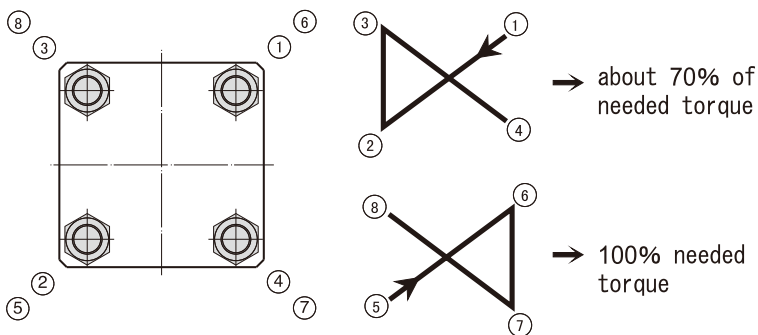

bore (mm)	32.40.50	63	80	
thread	M10x1.5	M12x1.5	M16x1.5	
needed torque (kgf-cm)	S45C	200	250	870
	S45C (QT)	280	510	1300

bore (mm)	100	125	150	
thread	M18x1.5	M22x1.5	M26x1.5	
needed torque (kgf-cm)	S45C	1300	2400	4500
	S45C (QT)	1800	3400	6400

## PIN AND KEEPER

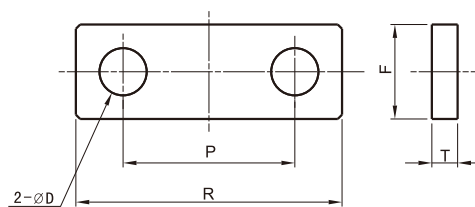
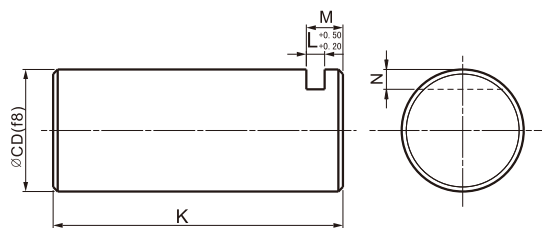

symbol bore	CD	K	M	N	L
32	16	57	7	3.5	3
40	16	57	7	3.5	3
50	20	68	7	3.5	3
63	31.5	76	9	5.5	6
80	31.5	76	9	5.5	6
100	40	95	12	6.5	6
125	50	143	12	7.5	6
150	63	183	18	10	9

symbol bore	D	F	T	P	R	
32	6.5	16	3	18	28	steel bolt M6
40	6.5	16	3	18	28	
50	6.5	16	3	18	28	
63	11	25	6	33	55	M10
80	11	25	6	33	55	
100	11	25	6	40	62	
125	14	25	6	50	72	M12
150	14	32	9	63	93	

ORDER INDICATION

MGHC	A	70		SD	C	100
series	type	working pressure	performance	installation form	shaft diameter	bore
Tie rod cylinder for magnetic sensors	A: Double acting cylinder C: Biaxial cylinder D: Double acting cylinder with adjustable stroke	70: working pressure 70kgf/cm <sup>2</sup> 140: working pressure 140kgf/cm <sup>2</sup>	blank = indicates standard  H: shaft with dust cover J: heat/acid & alkali resistance (max. tem. 150°C)	SD: Basic FA: Rod Flange FB: Head Flange CA: Clevis CB: Dual Clevis LA: foot flange LB: End flange TA: Rod Trunnion TC: Mid Trunnion	C: C diameter B: B diameter  note : 1. Standard cylinder HC-70 with C-shaft diameter 2. Standard cylinder HC-140 with C-shaft diameter 3. Please specify when HC-70+ B or HC-140+C	32: 32mm 40: 40mm 50: 50mm 63: 63mm 80: 80mm 100: 100mm 125: 125mm 150: 150mm

200ST				Txn		
stroke	cushion	shaft end joint	adjustable stroke	sensor & qty	port position	cushion position
blank = indicates standard Refer max. stroke in P.004	blank = indicates standard (no cushion) B: cushion on both ends R: cushion on rod cover H: cushion on head cover	Y: Y connector I: I connector Pin	Double acting cylinder with adjustable stroke length choose 25mm or 50mm	T: 2wires, 2meters P: PNP 3 wires, 2 meters N: NPN 3 wires, 2 meters N: qty 1. JFS-01 (standard) 2. JFS-01CC: (Separate switch (01AA+01BB))	blank = indicates standard pls refer to P.023	blank = indicates standard pls refer to P.023

Tie-rod Hydraulic Cylinder

Mold Hydraulic Cylinders

Swivel & Clamp Hydraulic Cylinders

Booster Cylinders & Unclamping cylinders

ISO Specifications Cylinders

Round Hydraulic Cylinders

Specific Hydraulic Cylinders

Systems & Fittings

blank = indicates standard

- note
- External dimensions according to HC standard tie-rod cylinder P.012~P.020
  - Installation form: SD.FA.FB.CA.LA.LB.TA.TC
  - Bore of MGHC2: 32~150mm
  - For all cylinders with magnetic sensors, to prevent sensor failure, please note the following points:
    - minimum stroke > 20mm
    - working temperature range: -25~+70°C
    - The cylinder cannot be installed in an environment where the magnetic field strength is greater than 1ka/m, and it is forbidden to place soft magnetic materials and soft magnetic iron filings nearby